

For reheat furnaces, process heaters, aluminum melters, etc. from 1800 F to 2600 F.

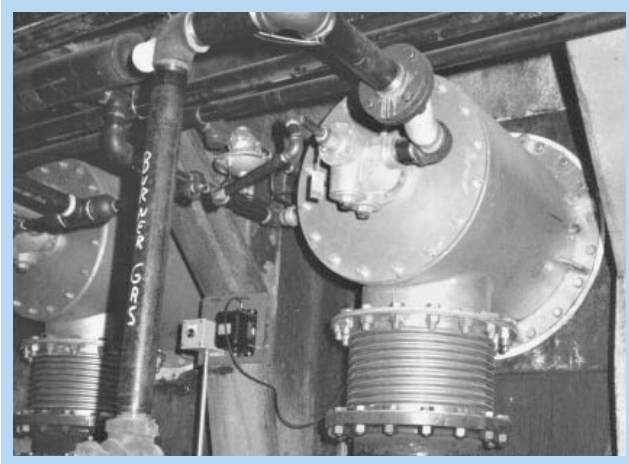

These Low NOx ATP Burners are firing a new hot strip mill reheat furnace.

ATP Burner bodies and backplates are fabricated of heavy gauge welded steel. Internal parts include a front refractory ring, refractory stabilizer, and an investment cast A330SST nozzle.

Burners use gas pressure to create a flame shape and heat pattern that is most advantageous for the furnace contour and application. A controlled flame shape is desirable in almost any application--it is essential in many to realize optimum furnace performance.

4482 ATP Burners are used with ambient temperature combustion air on a wide variety of furnaces operating up to 2600 F. For preheated air applications, refer to Bulletin 4472. Adaptive profiling principles enable these burners to vary flame configuration from approximately 750 000 Btu/hr per foot of length to 1 700 000 Btu/hr per foot. User can manually select optimum flame shape with the flame adjustment, which is an integral part of the gas connection.

**Adaptive Thermal Profiling (ATP)
distributes the heat where it' needed...
3 to 55 million Btu/hr.**

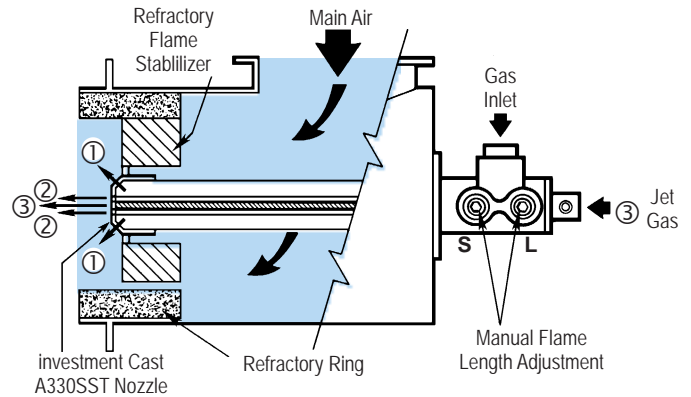

- ① Tangential gas--Increasing tangential gas flow (with flame adjustment screw **S**) shortens flame.
- ② Forward gas--Increasing forward gas flow (with flame adjustment screw **L**) lengthens flame.
- ③ Jet gas--used to maintain flame definition as input is reduced.

OPERATION

Burners are designed for 10"wc maximum recommended air pressure. Operation is quiet and the burner is stable over a wide range of air/gas ratios ranging from 30% fuel rich to 1000% excess air at 10"wc.

Stoichiometric turndown is 10:1 with 10"wc main air pressure (thermal turndown is extended to 15:1).

Standard design is for 8 psig gas at the burner.

A constant gas jet at 8 psi and 5% of maximum capacity maintains flame definition as input is reduced.

A low fire start is required at 1"wc or less main air pressure.

Burners are designed to be mounted no more than 15° from horizontal. Contact Fives North American if your application requires a greater angle.

**RANGE OF FLAME LENGTHS and DIAMETERS
(2000 F Furnace) in feet with 8 psig gas**
Air/gas ratio set for 10% excess air.

Burner designation	SHORT FLAME (10% reduced capacity) air pressure		LONG FLAME (full capacity) air pressure		FLAME DIA. (full capacity) long or short
	6"wc	10"wc	6"wc	10"wc	
4482-8	3 1/2	6	8	15	2.5
4482-9	5	8	10	15	2.5
4482-10-A	6	8	12	16	3
4482-10-B	7	9	15	18	3
4482-12	7	9	16	20	3
4482-14	9	12	18	24	3.5
4482-16	11	14	24	30	3.5
4482-18	14	18	28	34	4
4482-20	18	22	32	40	4
4482-22	20	25	36	45	4.5
4482-24	23	28	45	50	5

**COMBUSTION AIR CAPACITIES, scfh
long flame mode**

Capacities are reduced up to 10% in short flame mode.

Burner designation	air pressure		
	0.1"wc*	6"wc	10"wc†
4482-8	4 070	31 500	40 700
4482-9	7 150	55 300	71 500
4482-10-A	8 900	69 100	89 200
4482-10-B	11 300	87 700	113 000
4482-12	16 000	124 000	160 000
4482-14	20 000	155 000	200 000
4482-16	26 000	205 000	264 000
4482-18	33 000	261 000	337 000
4482-20	42 000	324 000	419 000
4482-22	51 000	361 000	509 000
4482-24	61 000	471 000	608 000

*min. air rate †max. recommended press.

CONTROL

Mass flow control is recommended. Standard 4482 ATP™ Burners have a single gas connection with internal tangential/forward gas adjustment for flame shaping.

Main and center jet gas should be supplied to the burner at the same time. See flow control schematic.

PILOT and FLAME SUPERVISION

Burners are ignited with a gas-boosted pilot. Pilot air pressure must be at least 10"wc, and pilot regulator must be cross-connected to the pilot air line (see Sheet 4014).

If flame supervision is used, pilot must be of the interrupted type. UV flame detection is recommended (using an 883—D adapter). It is possible for a UV scanner mounted on this burner to sight flame(s) of other burners in the same firing chamber. Consult Fives North American for configuration guidance on multiple burner applications.

LOW NOx

The 4482 ATP Burner is an inherently Low NOx burner. In conjunction with other NOx reducing features, it is capable of meeting emission limitations for new or retrofit applications in environmentally sensitive installations. Contact Fives North American for specific applications.

BURNER TILE CONSTRUCTION

4482 Burners do not include a tile. Tunnel shape and recommended installation is shown on Dimensions & Installation 4482.

OTHER FUELS

For other gaseous fuels and oils, contact Fives North America.

Typical Single Burner ATP Flow Control Schematic

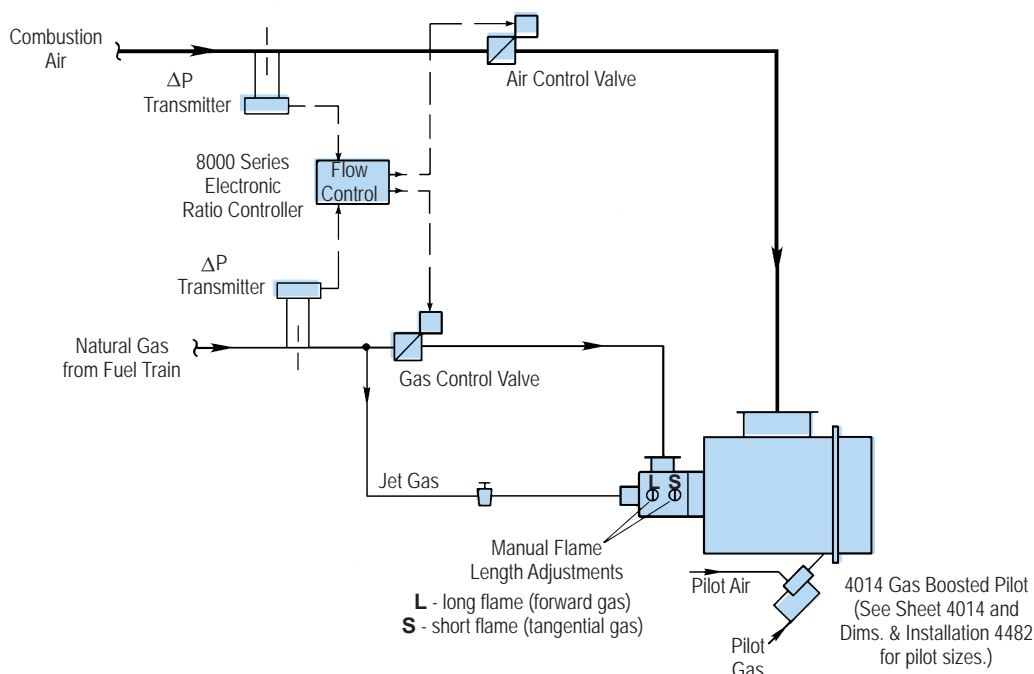

BURNER ADJUSTMENTS

1. The flame length adjusters are located on the side of the gas inlet connection. Initially set both the short (S) and the long (L) flame adjustment screws equally open. (Fully close both adjusters by turning them clockwise, then open 2 turns.)
2. Establish pilot flame. See Sheet 4014 for instructions.
3. Establish main flame. If main flame cannot be established, open (S) and (L) flame adjustment screws equally until a flame is established.
4. With an established flame, drive the system to high fire. Set air/fuel ratio. Using the (S) and (L) flame adjustment screws, make the desired flame length adjustments. If high fire gas flow cannot be reached, open the (S) and (L) flame length adjustment screws equally until the proper gas flow is obtained. Correct air/fuel ratio as required.
5. Drive the system to low fire. Set air/fuel ratio. If used, adjust jet gas valve to improve the low fire flame definition.
6. Drive the system to high fire and verify flame length and air/fuel ratio.

To order, specify: 4482-(code for pipe size)-(A, if applicable) Burner Complete (specify Arrangement Designators--see Dimensions & Installation 4482).

Examples: 4482-10-A 10" Burner Complete with arrangement 3a1
4482-12 12" Burner Complete with arrangement 1c3

WARNING: Situations dangerous to personnel and property may exist with the operation and maintenance of any combustion equipment. The presence of fuels, oxidants, hot and cold combustion products, hot surfaces, electrical power in control and ignition circuits, etc., are inherent with any combustion application. Parts of this product may exceed 160F in operation and present a contact hazard. Fives North American Combustion, Inc. urges compliance with National Safety Standards and Insurance Underwriters recommendations, and care in operation.