

LVDT/HC PILOT BURNER

External raw gas pilot burner



- Stable pilot flame in combination with MAXON AIRFLO® “LV”, “HC”, DELTA-TE™ and COMBUSTIFUME® burners
- Rugged design
- Burns natural gas, propane and LPG
- Suitable for all kinds of process air heating applications; thermal incinerators, supplementary firing burners etc...
- Complete stainless steel construction
- Plug & play design
- Optimal access for maintenance
- Factory-adjusted, no field refinements required
- Available in different tube lengths up to 4 m

Product description

The LVDT/HC-pilot burner is a nozzle mix pilot, designed to be mounted on AIRFLO® "LV", "HC", DELTA-TE™ and COMBUSTIFUME® burners.

The plug & play design provides extremely easy mounting and maintenance. All components including the spark ignitor, can be reached and/or replaced from outside the process air duct. The flame scanner can be isolated from the process by means of a stainless steel ball valve.

Once installed on the burner mounting flange, the 2" pilot tube of the LVDT/HC pilot penetrates through the process air stream into the burner endplate. Its complete stainless steel construction makes the LVDT/HC-pilot burner suitable for processes with high temperatures, humidity and/or pollutions.

Using fixed orifices, the LVDT/HC-pilot burner does not require adjusting of air and gas flows, reducing set-up times drastically.

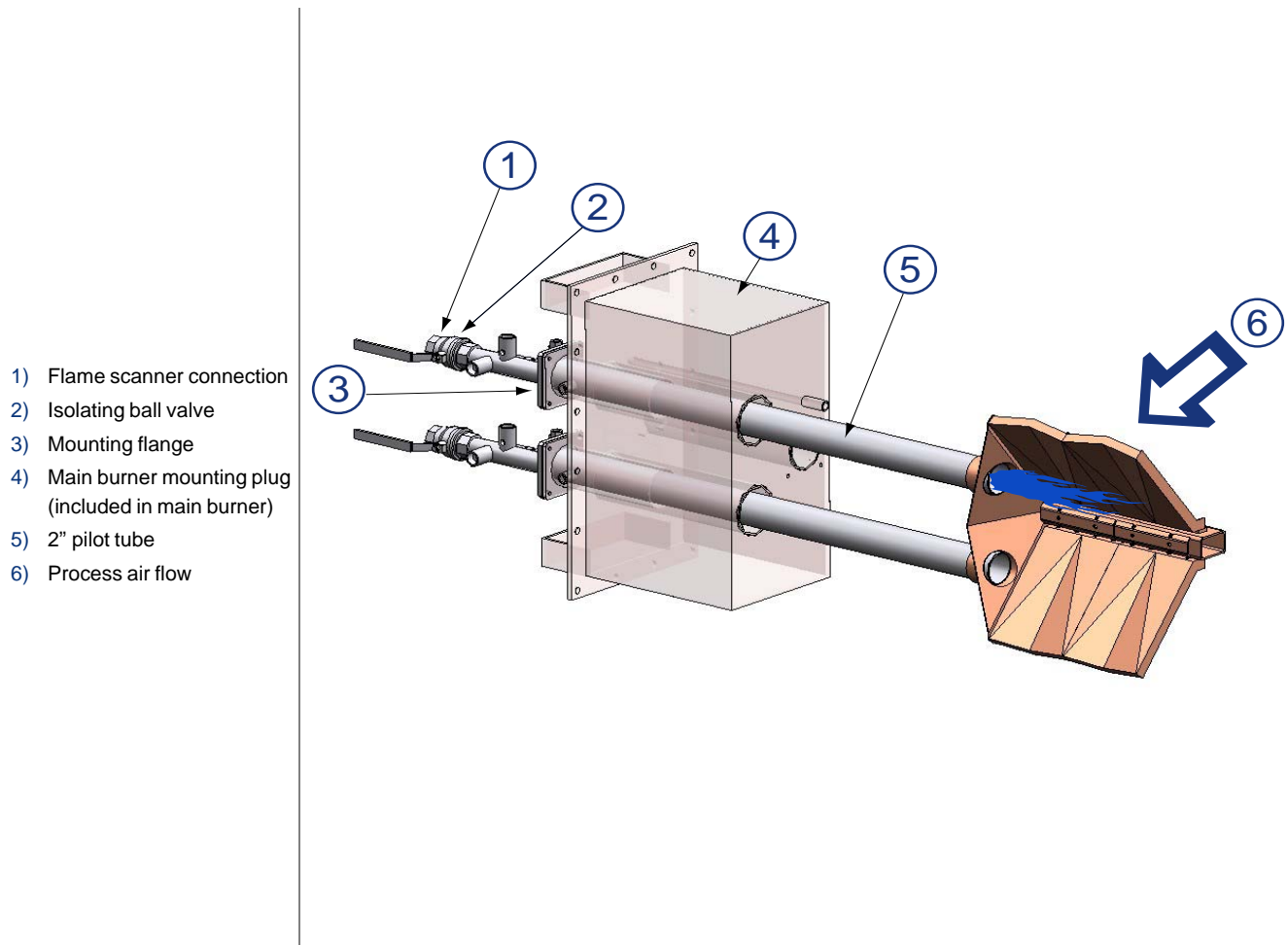

2 LVDT/HC-pilot burners mounted on a burner mounting plug, firing into a MAXON AIRFLO® "HC" line burner (burner mounting plugs standard available from MAXON on AIRFLO® "HC" and DELTA-TE™ burners).

Available LVDT/HC-pilot burner sizes

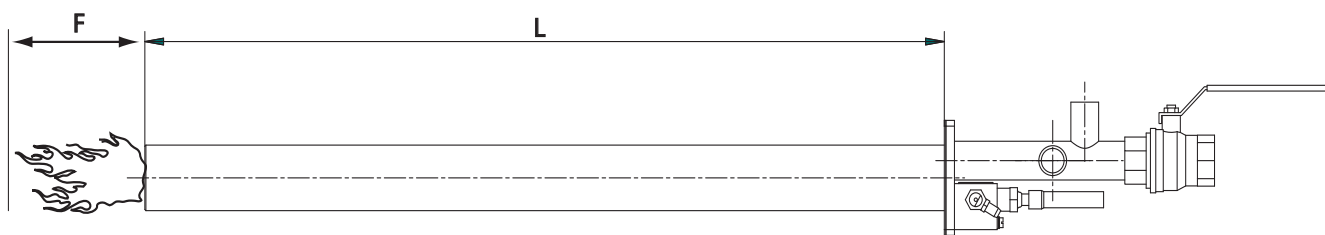

Dimensions in mm unless stated otherwise		
L	pilot tube lengths	450 - 600 - 750 - 900 - or customized
F	flame lengths	100 - 200

Pilot type designation: A-B-C-D-X-E		
A	LVDT	Low gas pressure inlet (30 mbar)
	HC	High gas pressure inlet (2 bar - 4 bar)
B	blank	Standard version for tube lengths X max. 1500 mm
	BSTD	Boosted version for tube lengths X between 1500 mm - 4000 mm
C	blank	ISO connections - European market (UV-scanner can detect spark)
	US	NPT connections - US-market (UV-scanner can not detect spark)
D	blank	For use in safe areas
	EEx	ATEX category 2G zone 1 & 2
X		Pilot tube length L
E	SM	For use with HC-S or HC-M type burners
	L	For use with HC-L type burners
	blank	For use with DELTA-TE™, AIRFLO® “LV” and COMBUSTIFUME®

Pilot burner / main burner compatibility

HC-X-L type pilot burners can only be used on AIRFLO® “HC” type L burners.

All other pilot burners are compatible with AIRFLO® “HC” type S and M, DELTA-TE™, AIRFLO® “LV” and COMBUSTIFUME® burners.

Read “Specifications of LVDT/HC-pilot burner” for more detailed information on LVDT/HC pilot burners.