

## Design Considerations

To properly select the appropriate type COMBUSTIFUME® Line Burner to meet your specific application requirements, these four factors must first be determined:

1. **Percent (by volume) of oxygen** remaining in air stream to be heated
2. **Allowable duct static pressure drop**, which is a direct relationship to the velocity of air across the burner and/or profile plate
3. **Air stream temperatures** approaching and downstream of the COMBUSTIFUME® Burner
4. **Type of fuel** to be fired through the burner

**Oxygen content and temperature of effluent/air stream dictates how and which COMBUSTIFUME® Line Burner must be applied.** Flammability of a raw gas burner is affected by oxygen content, air stream temperature and moisture content. Since a typical application for COMBUSTIFUME® Burners would involve an air stream temperature of 700°F or higher, air streams with measured oxygen levels above 16% (by volume) will normally support combustion by a raw gas burner and not require additional primary combustion air. However, if measured oxygen content in air stream is less than 16% or air stream temperature is less than 500°F, a percentage of partial premixed gas/air may be required to supplement the lower oxygen levels in your system for a complete combustion reaction to occur. Please refer to the Air Stream Flammability Chart on this page for the exact oxygen requirements of effluent/air streams.

**Elevated air stream temperatures approaching a COMBUSTIFUME® Burner can be as high as 1050°F (566°C).** This naturally causes changes in air density and net air velocities, and results in an effect on COMBUSTIFUME® Burner performance.

**The combination effect of lower inlet temperature and lower oxygen levels** will normally require a partial percentage of premixture be added through the COMBUSTIFUME® Burner system.

This combination effect (or air stream flammability) is graphically illustrated in the chart at right.

Since oxygen content within the air stream is critical to the flammability range of a COMBUSTIFUME® Burner, it also directly affects the maximum capacity (Btu/hr per lineal foot) of the burner assembly.

Any combination of temperatures and oxygen levels falling **above** the raw gas firing diagonal line should support combustion with a raw gas COMBUSTIFUME® Burner system.

Any combination of incoming temperature and measured percent of oxygen falling **below** the diagonal line will normally require the designated percentage of premixing through a COMBUSTIFUME® Burner system.

Notice: When primary combustion air is supplemented in the system, a corresponding work load increase must be factored into the gross heating requirement to heat the fresh combustion air being introduced.

**Air Stream Flammability Chart**

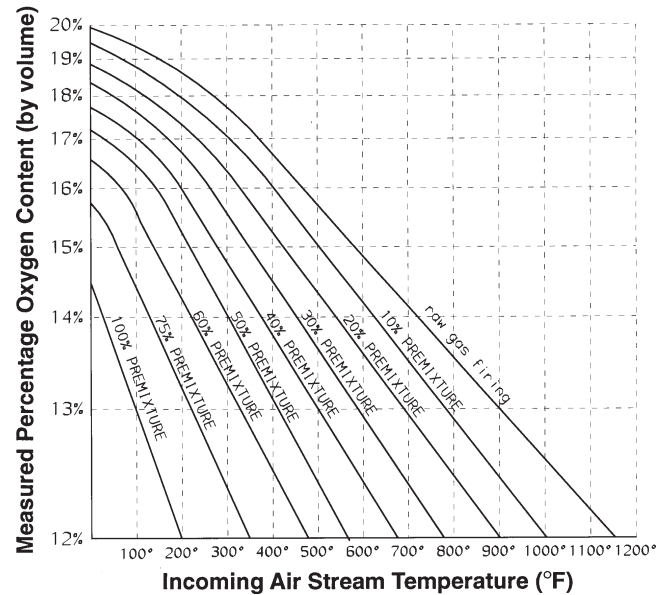

## Performance Selection Data

### General

**Air stream velocity and resulting pressure drop affect performance of COMBUSTIFUME® Burner systems.** This velocity across and through your burner’s mixing plates must be kept uniform and within desired limits by use of a (customer fabricated) silhouette profile plate through which the burner fires. A minimum 6" profile plate should be installed surrounding the interior duct walls at the leading edge of your burner’s mixing plates.

**Optimum design operating velocity ranges** are shown in preceding pages. The most accurate readings for velocities (in SFPM) are as measured with a velometer (or pitot tube) directly in the duct at the plane of the profile plate and leading edge of your burner’s mixing plates.

Since COMBUSTIFUME® Burner systems are installed in such widely diversified applications, it is often difficult to get into the chamber/duct and profile plate area to obtain the velocity pressure readings described above. For this reason, a close approximation of operating velocities may be made with a measurement of **duct static pressure drop**. Preferably, a static pressure test point one duct diameter in distance **upstream** from the profile plate and one duct diameter length **downstream** will give an approximation of operating velocity across the burner.

**These static pressure drops relate to velocity (in SFPM) as shown in Table 1 below.**

**CAUTION:** Do not try to take a differential static pressure reading from a test port at or near an elbow in the duct or chamber due to potentially erroneous readings caused by turbulence set up within the duct at such points. Measure in a straight duct with at least one duct diameter in length before and after the profile opening.

**For lower temperature rise applications,** determine profile opening area by adding burner displacement area (ft<sup>2</sup>/section) from page 5705 to net free area of your duct:

$$\text{Net free area of duct (ft}^2\text{)} = \frac{\text{Fan volume (SCFM)}}{\text{Velocity (SFPM)}}$$

**NOTE:** Various duct size/profile area relationships may give slightly different field site data than is shown in static pressure chart below.

**Table 1: Velocity (SFPM) relative to static pressure drop ("wc)**

<b>Approximate air stream velocity at burner profile plate (SFPM)</b>	<b>1000</b>	<b>1500</b>	<b>2000</b>	<b>2500</b>	<b>3000</b>	<b>3500</b>	<b>4000</b>
<b>Duct static pressure drop through profile opening ("wc) [1]</b>	0.1	0.2	0.4	0.6	0.9	1.2	1.6

[1] Based on profile/burner plane K factor of 0.8. May vary with your specific duct size/profile area relationship

## Design and Application Details

### COMBUSTIFUME® Line Burner Design Parameters

COMBUSTIFUME® Burner Type	Maximum Temperature Limits	Maximum Discharge Temperature	Maximum Static Pressure Drop
CF4D	1000°F (538°C)	1500°F (816°C)	2" wc
CF5D			2.5" wc
CF5D	1050°F (566°C)	1700°F (927°C)	2" wc
CF5B			

**Minimum capacity** is 150,000 Btu/hr per lineal foot of COMBUSTIFUME® Line Burner for “raw gas” burner systems.

**Differential gas pressure** (the difference between gas pressure inside COMBUSTIFUME® Burner manifold and the combustion chamber static pressure) **required in burner at maximum firing rates is shown in table below.**

**For raw gas firing in air streams where oxygen level exceeds 16% (for 24 hole drilling pattern)**

Maximum Capacity 1000's Btu/hr per lineal ft.	Differential Gas Pressures (inches wc)							
	Natural	Propane	2	2.9	4	5.2	6.6	8
	2	0.8	1.2	1.6	2.1	2.6	3.3	

**Effluent air streams with oxygen levels of 12% to 16%** may be heated with COMBUSTIFUME® Burner supplied with a partial premixture of air and natural or propane gas.

**A complete burner system** to handle these difficult applications would include a COMBUSTIFUME® Burner assembly, Series “HG” Mixing Tube, MICRO-RATIO® Control Valve and a combustion air blower as shown below. Your Maxon representative can help you select from the broad range of options available.

#### “HG” Mixing Tube System for partial premixed COMBUSTIFUME® Burner system

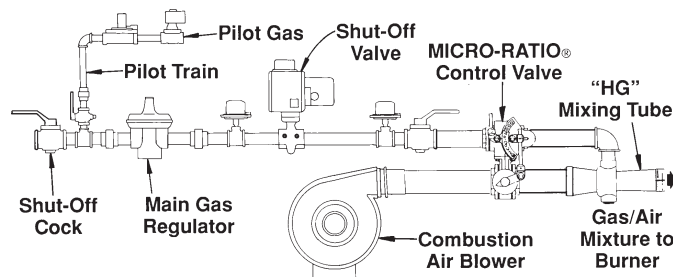

**Thermal expansion due to the high operating temperature of incineration units requires special care** in manifold and combustion chamber design. Flexible connections between manifold and burner assembly inlets are recommended, and provision should be made in burner support to allow for growth with temperature.

**Flame supervision by UV scanner is preferred, and must be used** whenever effluent inlet temperatures exceed 600°F (316°C). Cooling or purge air to the scanner connection is recommended. Flame rods can be mounted through pilot assembly, but are limited to 600°F (316°C) effluent inlet temperature.

Observation and access are both important to a successful installation. Ability to view the flame from downstream of burner (particularly pilot location) greatly simplifies start-up and operating procedures, while access to upstream side of burner facilitates eventual maintenance.

#### Displacement area per section

For purposes of calculating operating air velocities and resulting static pressure drops across the burner assembly and profile plate, use the following equivalent displacements:

- Each 6" straight section: 0.35 ft<sup>2</sup>
- Each 12" straight & 12B section: 0.7 ft<sup>2</sup>
- Each 12" x 6" tee section: 0.75 ft<sup>2</sup>
- Each 12" x 12" cross & BX section: 0.85 ft<sup>2</sup>
- Each 36" B H section: 1.5 ft<sup>2</sup>

Maxon assumes no responsibility for the use or misuse of the piping layouts shown. Specific piping and wiring diagrams should always be submitted to the appropriate agencies for approval on each application.

## Performance Selection Data

### Series "HG" Mixing Tubes with partially premixed COMBUSTIFUME® Burner system in 12 – 16% oxygen level air stream applications

#### General Selection Procedure:

- Determine available oxygen level in air stream to be heated.
- Enter Table 1 under column with specific oxygen level for parameters of your application. Available oxygen level dictates combustion air and extra heat requirements for additional primary air flows.
- Calculate gross heat requirement.
- Determine burner footage and inlet feed requirements.
- Select "HG" Mixing Tube size from Table 2 based upon the volume of combustion air required.

Table 1: Design Parameters

Percent of oxygen in effluent:	12 to 12.9	13 to 13.9	14 to 15.9
Required increase in gross heat release (Btu/hr)	10%	7.5%	5%
Maximum heat release per lineal foot of burner (Btu/hr)	700,000		1,000,000
Minimum heat release (Btu/hr) per lineal foot of burner	75,000		
Combustion air required through Series "HG" Mixing Tube (SCFM per lineal foot of burner)	47	41	34
Differential air pressure required (inches wc) as measured between burner inlet and duct/chamber static pressure	8	6.4	5.5

#### Example:

- Required heat release of 7,000,000 Btu/hr
- For system measured with 13.5% oxygen in air stream

From Table 1 (13 to 13.9%, middle column)

- A. Gross heat required  
7,000,000 x 1.075 = 7,525,000 Btu/hr
- B.  $\frac{7,525,000 \text{ Btu}}{700,000 \text{ Btu/ft}} = 10.75 \text{ ft.} = 11 \text{ ft.}$  of burner
- C.  $\frac{11 \text{ ft.}}{6 \text{ ft/inlet}} = 2 \text{ inlets}$
- D. 11 ft. x 41 SCFM/ft = 451 SCFM primary air with differential pressure = 6.4" wc

From Table 2 (400 to 1167 SCFM)

- E. Select 6" HG Mixing Tube with 12 each 29/64" gas orifices per Table 3
- F. Select MICRO-RATIO® Control Valve
- for 451 SCFM air = (27060 SCFH)
  - for 7525 SCFH natural gas

Table 2: Series "HG" Mixing Tube Selection

"HG" Mixing Tube Size	SCFM combustion air volume required at maximum through "HG" Mixing Tube
2"	0 to 190
3"	90 to 260
4"	175 to 500
6"	400 to 1167
8"	880 to 2500

Table 3: Gas Orifice Drillings for Series "HG" Mixing Tubes

NOTE: Drillings below based on 2 PSIG inlet gas pressure (measured at "HG" Mixing Tube gas inlet)

Size of "HG" Mixing Tube (number of gas orifices in parentheses)	For partially premixed systems			
	Combustion Air Pressure measured at air inlet of "HG" Mixing Tube	Gas Orifice Drillings for Series "66" AIRFLO® and COMBUSTIFUME® Burners		
		for Natural Gas	for Propane Gas	for Butane Gas
2" HG (4)	6 & 8 osi	21/64"	I	F
3" HG (6)		21/64"	I	F
4" HG (8)		7/16"	T	R
6" HG (12)		29/64"	3/8"	T
8" HG (12)		35/64"	29/64"	7/16"

## Performance Selection Data

### Raw gas firing of COMBUSTIFUME® Burners in air streams with 16+% oxygen levels

#### Profiling for higher temperature applications

When calculating profile dimensions for COMBUSTIFUME® Burner systems in applications with higher inlet air temperatures, greater temperature rises, and/or variable air stream volumes, the air with elevated temperatures and densities must be considered.

#### Sample Calculations

A sample procedure for designing a raw gas COMBUSTIFUME® Burner system for a thermal fuel incinerator (with 16+% oxygen level) is provided below.

#### General Selection Procedure

- Determine available oxygen level in air stream to be heated.**  
For a raw gas application, we will use 16+% oxygen level.
- Determine the SCFM of air through the incinerator. Include any variations in this flow.**  
For our calculations, we will use a constant volume air fan of 5000 SCFM.
- Determine inlet temperature of effluent to COMBUSTIFUME® Burner.**  
We will use inlet temperature of 700°F.
- Determine outlet or discharge temperatures from the incinerator.**  
For our example, we will design for 1500°F.
- Determine the volume of any combustible hydrocarbons in the effluent air stream.**  
We will use 20 gallons of evaporated solvent per hour @ 110,000 Btu/gallon.
- Determine available gas pressure and its anticipated pressure drop through the control system's piping and valves.**  
For this example, we will use 5 PSIG natural gas supply pressure available; 3" wc pressure drop through control system; +3" wc static pressure in combustion chamber; 8" wc differential gas pressure required to burner and 14" wc gas pressure required from main gas regulator (at maximum burner firing rate).

#### 7. Calculate maximum total heat required

$$\text{Btu/hr} = \text{SCFM} \times \text{"K"} \\ \text{(from step 2)} \quad \text{(from chart below)}$$

Multiply SCFM of air by multiplier (K), which combines hypothetical available heat at 1500°F and a 1.08 composite air heating factor to give the value in Btu required being "gross heating value" of fuel. Since multiplier (K) varies with inlet and discharge air temperature, the various factors are graphically shown below:

#### For 1300°F, 1500°F and 1700°F discharge temperatures

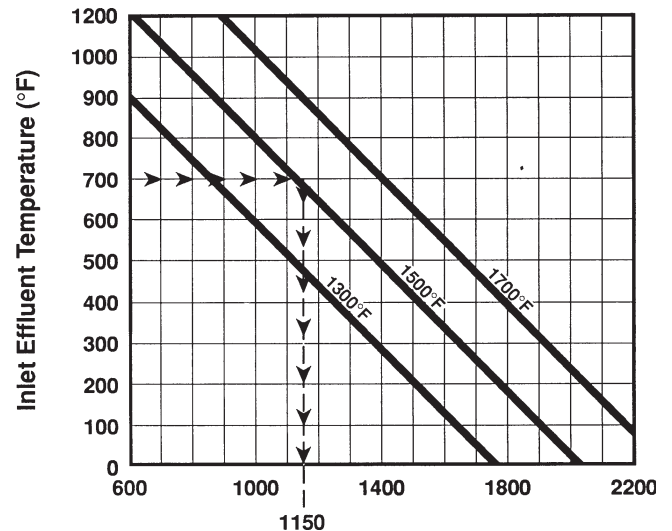

$$\text{Evolution of "K"} = \left( \frac{\text{CFH gas}}{\text{SCFM air}} \right) \times 1000$$

Enter chart at 700°F inlet temperature line (from step 3); follow across to intersect the 1500°F discharge temperature sloped line, then drop straight down to read the "K" multiplier factor of 1150.

Therefore, maximum heat input required:

$$\text{Btu/hr} = 5000 \text{ SCFM} \times 1150 = 5,750,000$$

## Performance Selection Data

### Design procedure and calculation example (continued)

**8. Determine the COMBUSTIFUME® Burner footage**

Divide the maximum Btu/hr (calculated in step 7) by 1,000,000 Btu/hr per lineal foot. Round-up to the nearest whole foot (if necessary).

$$\text{Required Burner Footage} = \frac{5,750,000 \text{ Btu/hr (from step 7)}}{1,000,000 \text{ Btu/lineal foot}}$$

$$\begin{aligned} \text{Required burner footage} &= 5.7 \text{ lineal feet} \\ &= (\text{round-off to 6 lineal ft.}) \end{aligned}$$

**9. Lay out a proposed burner assembly using these general guidelines:**

- A. Use as few tee sections as possible to conform to general shape of the combustion chamber.
- B. Minimize use of cross or back inlet cross sections for general fume incineration applications, since they do not provide the same degree of exposure to the flame achieved by straight or tee sections.
- C. If multiple burner rows are used, they should be placed on 12" centers to avoid need for between-the-row profile plate baffles.
- D. **Do not** exceed 3,500,000 Btu/hr capacity for any **2" diameter end inlet flange**.
- E. **2" diameter back inlet flange and INCINO-PAK® inlet feed section** should feed no more than 7,000,000 Btu/hr capacity.
- F. **3" diameter back inlet flange** on "12B" section can feed up to a maximum of 10,000,000 Btu/hr, or 8,300,000 Btu with any 36BH section.
- G. Keep burner assembly balanced and as symmetrical as possible around all inlet feeds.
- H. Ductile iron 12" x 12" back inlet cross must not be mated directly to another ductile iron 12" x 12" back inlet cross.

**NOTE:** Several possible burner arrangements could be devised. For this example, we will propose the burner layout illustrated below:

**Example: 6 lineal feet**

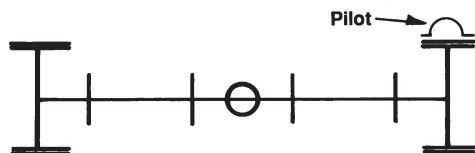

**10. Determine total burner displacement area by adding the displacement area of all the individual sections (see page 5705)**

Area displaced by this assembly:

$$(2) \text{ 12" x 6" tee sections @ } 0.75 = 1.50 \text{ ft}^2$$

$$(3) \text{ 12" straight sections @ } 0.7 = 2.10 \text{ ft}^2$$

$$\text{Total Area} = 3.60 \text{ ft}^2$$

**11. Determine dimensions of profile plate opening using these general guidelines:**

- A. Profile opening should be 1" longer than nominal length of burner assembly (dimension X + 1" in the sketch below)
- B. Edge of profile plate should be 6-1/2" from centerline of any "outside row" of castings

**"Typical Configuration" Example:**

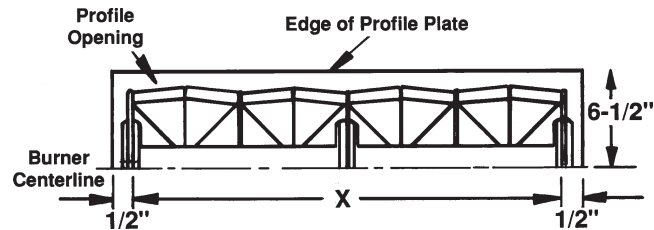

**Example: 6 lineal feet assembly**

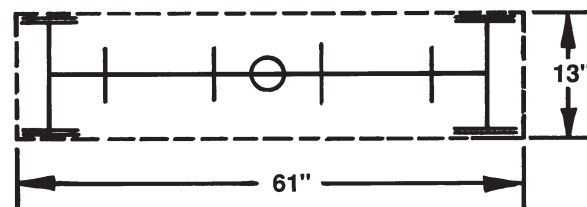

**12. Calculate gross area of profile plate opening**

$$\text{Sq. ft. area} = \frac{\text{inches length} \times \text{inches width}}{144 \text{ sq. in. / sq. ft.}}$$

**If we assume a gross profile area of 13" x 61"**

**Gross area of opening in profile plate**

$$= \frac{13" \times 61"}{144 \text{ in}^2/\text{ft}^2} = 5.51 \text{ sq. ft.}$$

## Performance Selection Data

### Design procedure and calculation example (continued)

**13. Calculate the velocity of flow of the effluent over the burner and through profile opening**

$$\text{Velocity (SFPM)} = \frac{\text{SCFM (from step 2)}}{\text{Profile Area (from step 12)} - \text{Burner Displacement (from step 10)}}$$

**Velocity of Effluent:**

$$\text{SFPM} = \frac{5000 \text{ SCFM}}{5.51 \text{ ft}^2 - 3.62 \text{ ft}^2} = 2645 \text{ SFPM}$$

**14. Check the duct static pressure drop across the burner assembly and profile plate**

In Graph "B" below, check to see whether the velocity determined in step 13 and the inlet effluent temperature (step 3) result in a pressure drop within the shaded (acceptable) area. Conditions in the shaded area are permissible.

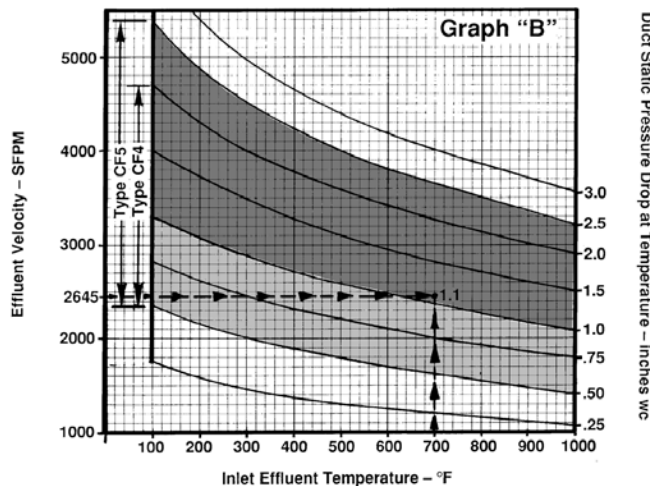

Optimum pressure should be in the 1 - 1.5" range.

- If the pressure drop is too high, the profile opening must be increased.
- If the pressure drop is too low, the profile opening must be reduced.

**NOTE:** Chart is based on tight profiling. If sizeable gap is maintained around burner, pressure drop will be less than indicated in Graph "B".

**Pressure drop across burner and profile plate (refer to Graph "B")**

$$(2645 \text{ SFPM @ } 700^\circ\text{F}) = 1.1" \text{ wc drop}$$

It would be better to change the opening to

12-1/2" x 60", which would increase pressure drop as follows:

$$\text{Area} = \frac{12.5" \times 60"}{144 \text{ in}^2/\text{ft}^2} = 5.21 \text{ ft}^2$$

$$\text{SFPM} = \frac{5000}{5.21 - 3.62} = 3200$$

**Pressure drop = 1.9" wc**

**15. Check the minimum Btu/hr per lineal foot required**

$$\frac{\text{Btu/hr per foot} = \frac{\text{Maximum heat (from step 1)} - \text{Btu/hr available from solvent (from step 5)}}{\text{Footage of burner (from step 8)}}}$$

$$\text{Minimum Btu/hr per ft.} = \frac{5,750,000 - (20 \text{ gal.} \times 110,000)}{6 \text{ ft.}} = 591,667$$

If above figure falls below 150,000 Btu/hr per ft., burner footage must be reduced and/or a compromise of other design parameters must be made. Our example is well above the 150,000 limit, so the turndown range of a standard COMBUSTIFUME® Burner system should be adequate.

**16. Select the proper type COMBUSTIFUME® Burner from these general guidelines:**

**Type of COMBUSTIFUME® Burner:** With inlet effluent

COMBUSTIFUME® Burner Type	Maximum Inlet Temperature	Maximum Discharge Temperature	Maximum Static Pressure Drop
CF4D	1000°F (538°C)	1500°F (816°C)	2" wc
CF5D			2.5" wc
CF5B	1050°F (566°C)	1700°F (927°C)	2"

temperature of 700°F, discharge temperature of 1500°F, and a pressure drop of approximately 1.9" wc for burner assembly selected:

**Use Type CF4D COMBUSTIFUME® Burner**

## Capacity/Selection Data

Based on capacity information given in this catalog section, and within the constraints of duct size and air volume flows, a COMBUSTIFUME® Burner assembly is designed utilizing these available sections shown on the following pages.

**When ordering a burner assembly** made up from these available module components, be sure to provide an assembly sketch of the complete burner (as viewed from the back, or upstream, side), including locations of all accessories and/or individual component sections.

**All open ends of burner assembly must be closed off with one of the end closures or pilot assemblies** shown on the following pages. Any end plate ports not used must be plugged.

**Air stream velocity** and resulting static pressure drop affect performance and are achieved by means of a silhouette profile plate within the duct.

**A minimum profile plate width of 6" is required surrounding all COMBUSTIFUME® Burner assemblies.**

**Burner inlet feed piping** must be adequate to provide a well-distributed flow of air/gas throughout the burner assembly. Burner assembly layout should be

symmetrical and balanced with relation to inlet feed sections.

Ductile iron 12" x 12" back inlet cross must not be mated directly to another ductile iron 12" x 12" back inlet cross.

Do not exceed the capacity feed limitations shown in the table below.

### Raw gas firing capacity limitations for inlet feed sections

COMBUSTIFUME® Burner		Maximum Btu/hr per inlet
Inlet Pipe Size (NPT)	Burner Section	
2"	End inlet flange set	3,500,000
	12" straight (12B)	7,000,000
	INCINO-PAK® (12B & 36B)	
3"	36" back inlet (BH)	8,300,000
	12" straight (12B)	10,000,000
4"	12" x 12" cross (XB)	12,000,000

Inlet flanges bolt directly to burner body casting and accept threaded NPT piping. Chart above shows maximum lineal feet of COMBUSTIFUME® Burner that may be fed by a given inlet flange.

## COMBUSTIFUME® Line Burner Designation

The designation of each COMBUSTIFUME® Burner section identifies specifics about that section.

**Example:** 12" x 12" bk inlet section CF 5 - BX - D - 24

**Section Description**

**CF** = COMBUSTIFUME® Burner  
**IP-CF** = INCINO-PAK® Burner

**Mixing Plate Material**

**4** = #310 stainless steel  
**5** = Hastelloy-X

**Section Code**

**6** = 6" straight section  
**12** = 12" straight section  
**T** = 12" x 6" tee section  
**X** = 12" x 12" cross section  
**12B** = 12" back inlet straight section  
**BX** = 12" x 12" back inlet cross section  
**BH** = 36" back inlet "H" section

**Body Material**

**D** = ductile iron body  
**B** = aluminum bronze body

**Number of (#30) drilled holes per lineal foot**

**24** = 24 holes (0.3113 in<sup>2</sup>/ft) discharge area  
**48** = 48 holes (0.6226 in<sup>2</sup>/ft) discharge area [1]  
**96** = 96 holes (1.2451 in<sup>2</sup>/ft) discharge area [1]  
**120** = 120 holes (1.5564 in<sup>2</sup>/ft) discharge area [1]

[1] These drill patterns available for special applications such as low Btu/fuels and partial premixing system



## Performance Selection Data INCINO-PAK® Burner Inlet Feed Sections

INCINO-PAK® Burner sections are special configurations of 12" or 36" back inlet feed sections. They provide "outside-the-duct" access to the raw gas pilot, ignitor, and flame safeguard components, eliminating lateral duct wall connections.

INCINO-PAK® Burner sections are designed to feed COMBUSTIFUME® Burner elements in end-fired incinerators or preheaters with cylindrical combustion chambers, or when burner is fired at an elbow in the ductwork.

INCINO-PAK® Burner sections can be used alone (with appropriate end plates and accessories added), or as an inlet feed section in a larger COMBUSTIFUME® Line Burner assembly.

All INCINO-PAK® Burner sections contain a 2" (NPT) gas inlet connection which may be used to feed up to a maximum capacity of 7,000,000 Btu/hr.

Heat release and gas pressure requirements match those of the other COMBUSTIFUME® sections. The raw gas pilot capacity is 25,000 Btu/hr.

**WARNING: Pilot gas should be interrupted once main flame is established. UV sight tube must be sealed against any scanner cooling air used.**



36" back inlet "H" INCINO-PAK® Burner section shown with (4) COMBUSTIFUME® Burner end plates; includes spark ignitor, pilot gas adjustable orifice cock, raw gas pilot, and arranged for mounting of customer's UV scanner

Three manifold lengths are offered in both the 12B and 36B back inlet INCINO-PAK® Burner sections:

**Series 600** = 600 millimeter (23.8") length

**Series 800** = 800 millimeter (31.5") length

**Series 1100** = 1100 millimeter (43.3") length

This "manifold length" reflects the distance between the outside duct mounting wall and the centerline of the COMBUSTIFUME® Burner casting. See catalog page 5712 for specific dimensions.

Each INCINO-PAK® Burner section includes a spark electrode, adjustable pilot gas orifice, body gasket, and provision for your UV scanner.

### Typical block & bleed piping layout for raw gas INCINO-PAK® Burner system as frequently required by insurance authorities

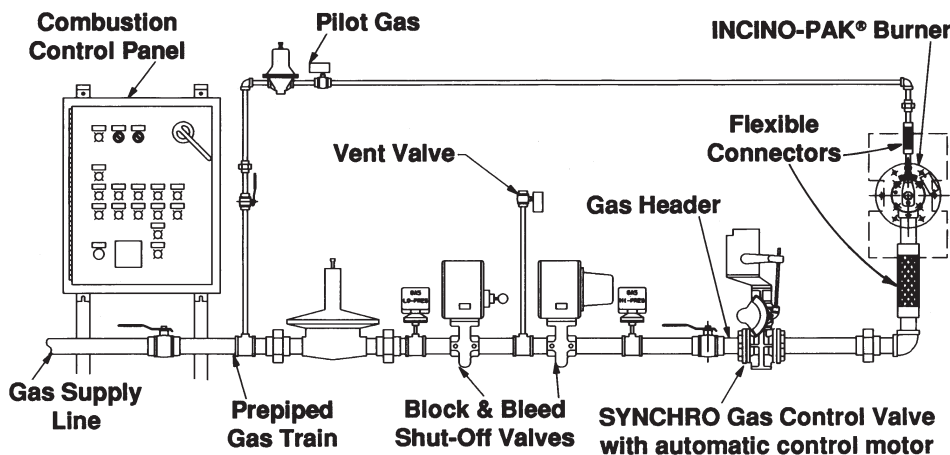

### Typical installation in cylindrical incinerator

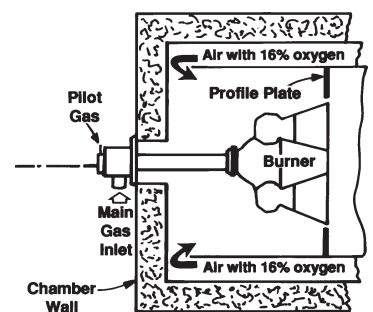

Maxon assumes no responsibility for the use or misuse of the piping layout shown. Specific piping and wiring diagrams should always be submitted to the appropriate agencies for approval on each application.

## Dimensions (in inches) INCINO-PAK® Burner Back Inlet Sections

### 36" back inlet "H" section

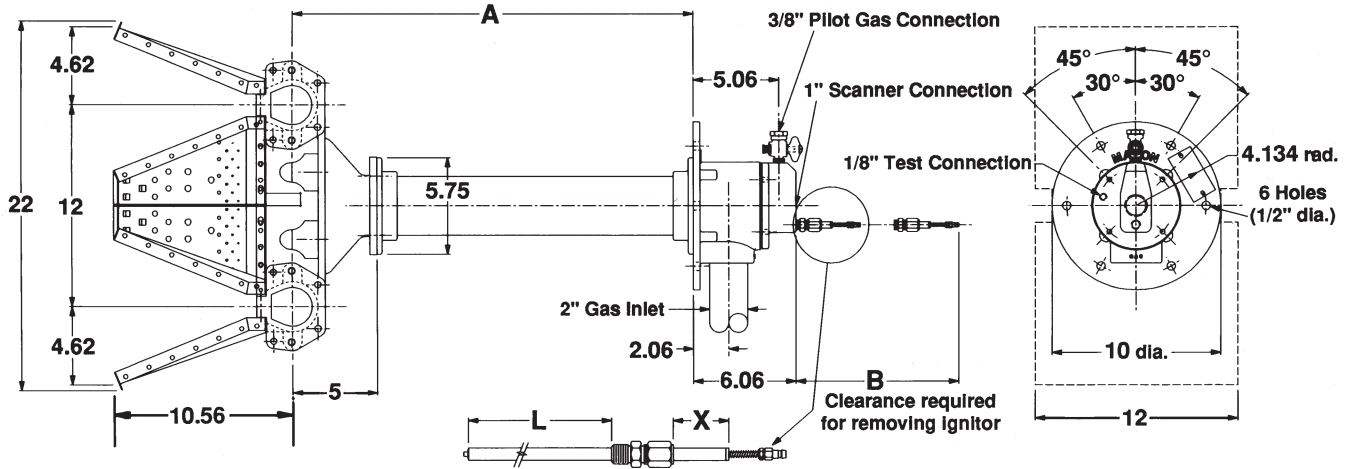

### 12" back inlet "12B" section

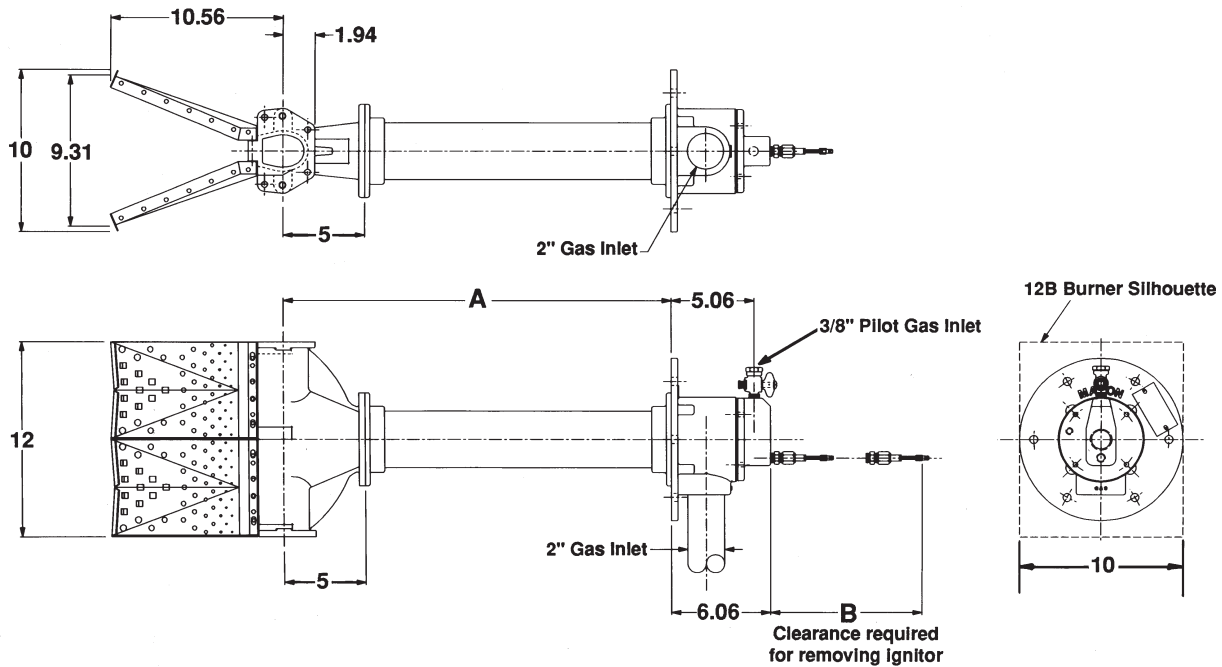

Pipe threads on this page conform to NPT (ANSI Standard B2.1)

Series	A	B	L	X
600	23.81	37.25	31.65	1.5
800	31.5	45.25	39.34	1.75
1100	43.31	56.25	51.15	1

## Envelope Dimensions (in inches) Modular Burner Sections



**6" straight section**

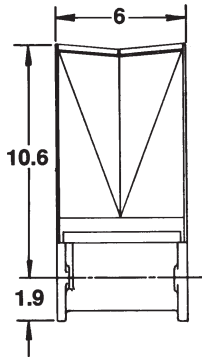

**12" straight section**

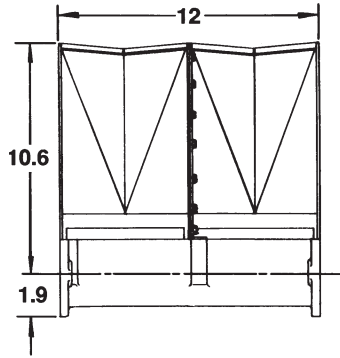

**12" x 6" tee section**

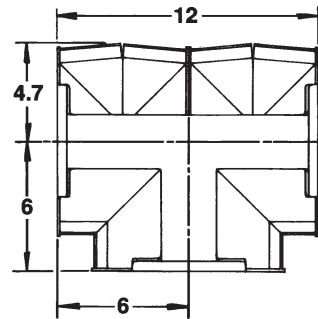

**12" x 12" cross section**

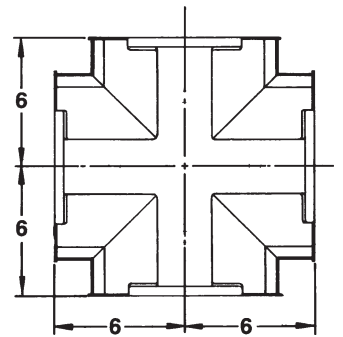

### Typical End Views

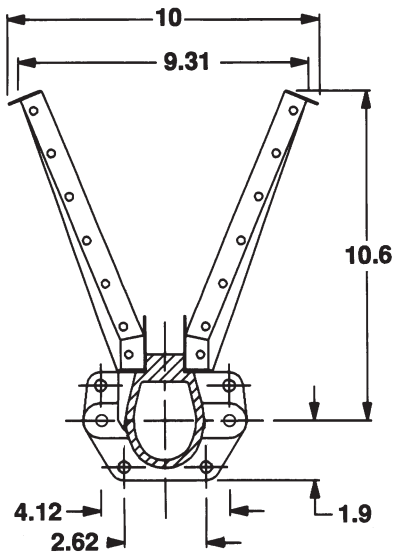

**Straight Sections**

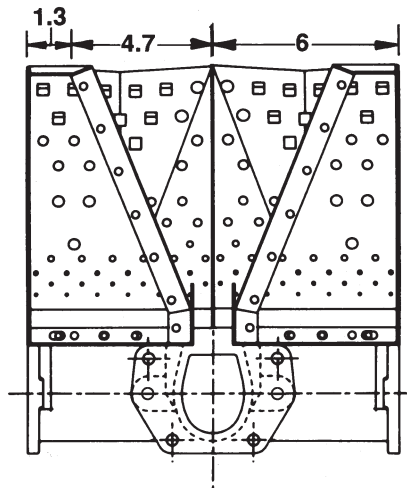

**Tee and Cross Sections**

## Envelope Dimensions (in inches) Modular Inlet Feed Burner Sections



12" back inlet section

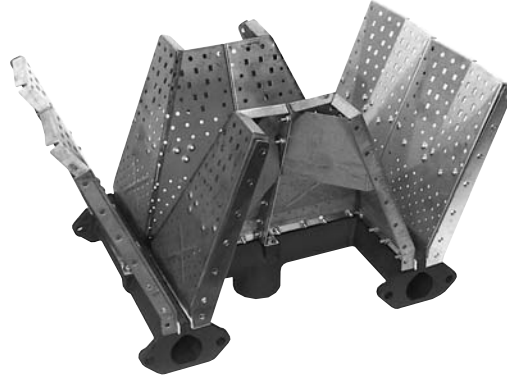

36" back inlet section



12" x 12"  
back inlet cross

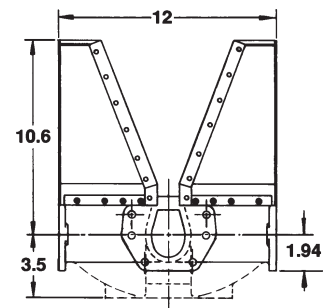
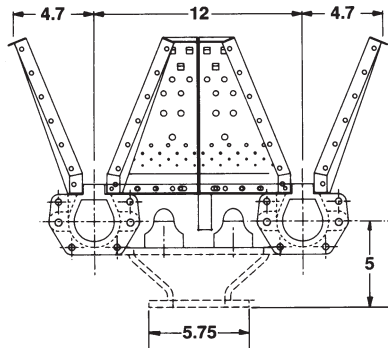
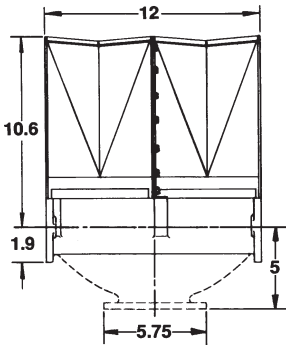

**NOTE:** 12B, 36B and XB back inlet sections must be ordered with one of the back inlet flange sets shown below.

### Back Inlet Flanges

#### Flange Sets for 12" & 36" Back Inlet Sections



2"  
LFB



3"  
LFB

Inlet flanges bolt directly to burner casting and accept either standard NPT or standard ISO threaded piping of indicated size.

NOTE: Refer to page 5710 for specific inlet feed capacity limitations.

#### Flange Sets for 12" x 12" Back Inlet Cross Sections



3"



4"

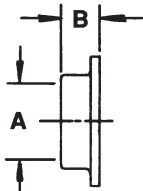
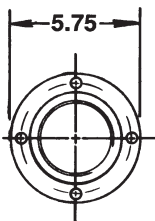

A (size)	B
2	0.88
3	1.25

A (size)
3
4

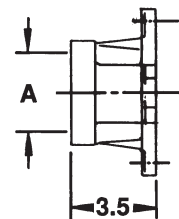
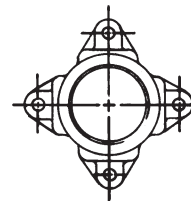

## Envelope Dimensions (in inches) End Closures and End Inlet Flange Sets

All open ends of a burner assembly must be closed off with one of these end closures, or with a pilot end plate or pilot assembly as shown below and on page 5716.

### Plain end plate set

Plain end plate closure includes 1/8" NPT test connection

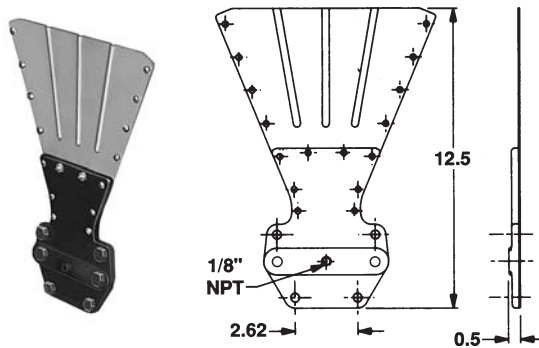

### Pilot end plate set

UV scanner can be mounted through straight-in flame rod location. 1" tap is bushed to 1/4" for flame rod.

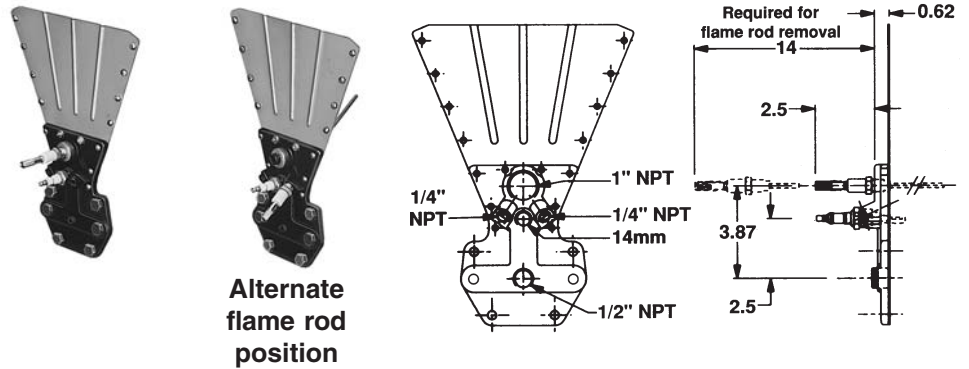

**Flame rods ( if used) must be ordered separately with all pilot end plate sets.**

### Inlet pilot set

UV scanner can be mounted through straight-in flame rod location. 1" tap is bushed to 1/4" for flame rod.

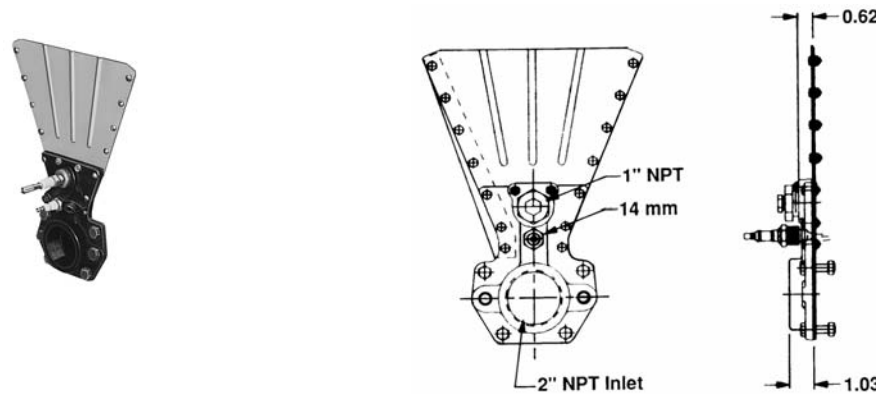

**NOTE: See catalog page 5710 for specific inlet feed capacity limitations.**

## Envelope Dimensions (in inches)

### Pilot Assemblies

#### Built-in pilot arrangements

**Direct mounted** version includes 14mm spark ignitor. Order electrode separately for externally mounted version. Order flame rod (if used) separately.

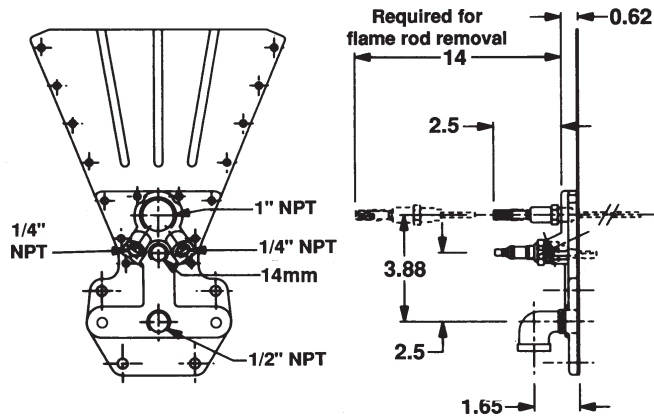

**NOTE:** Built-in pilot assemblies must mount **only** where COMBUSTIFUME® Burner sections provide for the segmented gas chamber within the burner body casting. See sketches below relative to possible locations for built-in pilot assemblies.

#### Built-in pilot detail

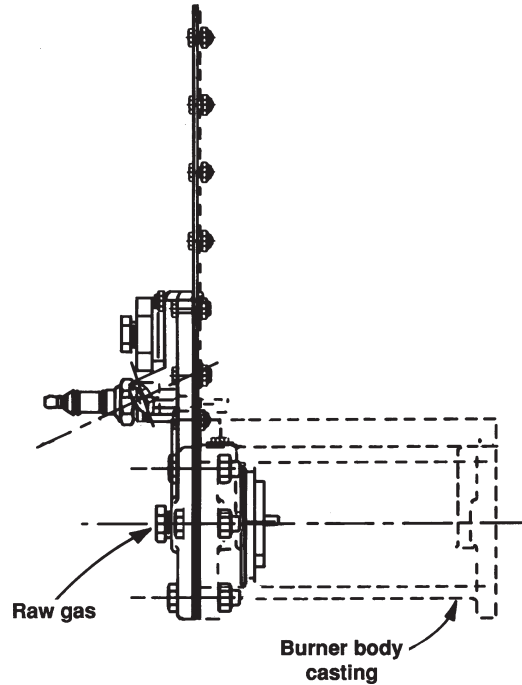

#### Optional external mounting assemblies shown on page 5718

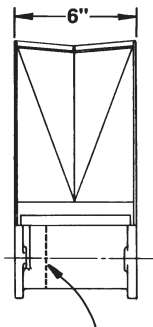

**All 6" straight sections**, whether gray iron, ductile iron, or aluminum bronze, can accept built-in pilots on **one** end.

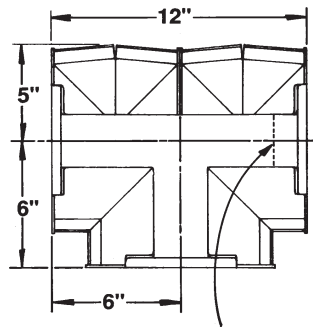

**Aluminum bronze 12" x 6" tee section** can accept built-in pilot only on **right end** of straight 12" side (when viewed from back side of the assembly).

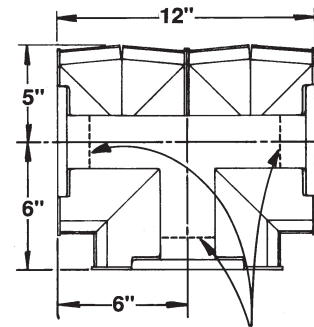

**Ductile iron 12" x 6" tee sections** can have built-in pilot assembly mounted on **any** end.

**NOTE: Gray iron tee sections do not accept built-in pilot assemblies.**

## Envelope Dimensions (in inches) Pilot Assemblies

### AIRFLO-PAK pilot arrangements

**Direct mounted version** includes 14mm spark ignitor. Order electrode separately for **externally mounted** version. Order flame rod (if used) and pilot mixer separately.

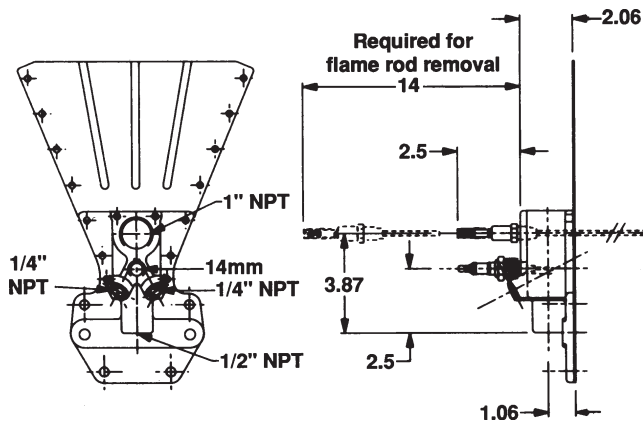

### Optional air/gas pilot mixers

for all COMBUSTIFUME® Burner AIRFLO-PAK pilot assemblies

#### Pressure type with adjustable orifice

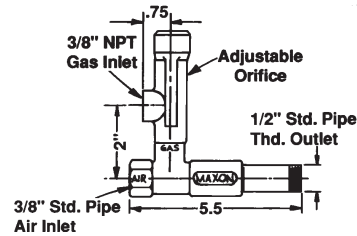

#### Atmospheric type with fixed orifice

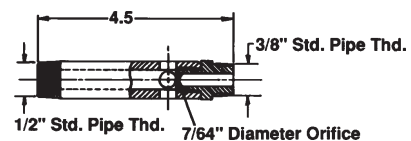

## External Mounting Plate Assemblies

**External mounting plate details** – A plate is included with all assemblies shown on page 5718



Mounting Plate with two (2) feed-through insulators for internal mounting of spark ignitor and flame rod. Same size external mounting plate used in all assemblies shown on page 5718.

**Positioning mounting plate** in relation to AIRFLO® Burner pilot location

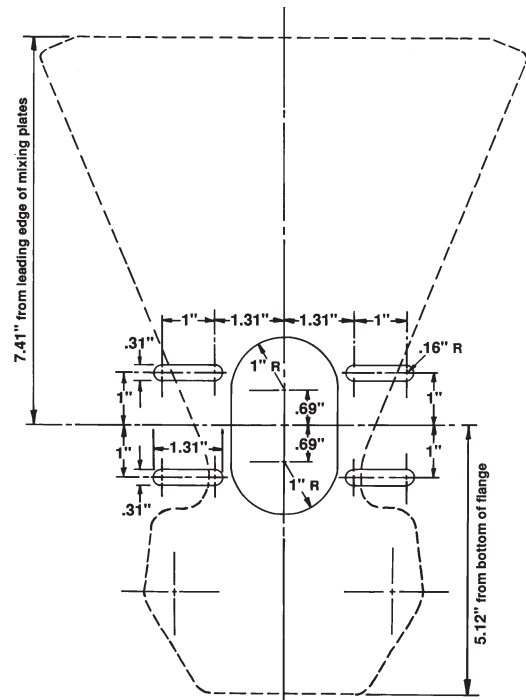

### External mounting plate dimensions

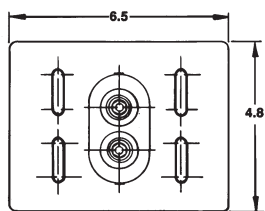

### Through-wall opening required

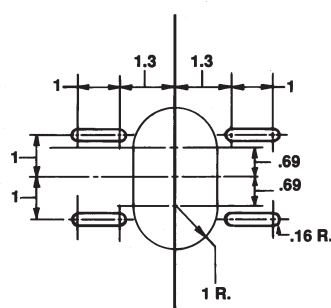

## Dimensions (in inches) External Mounting Plate Assemblies

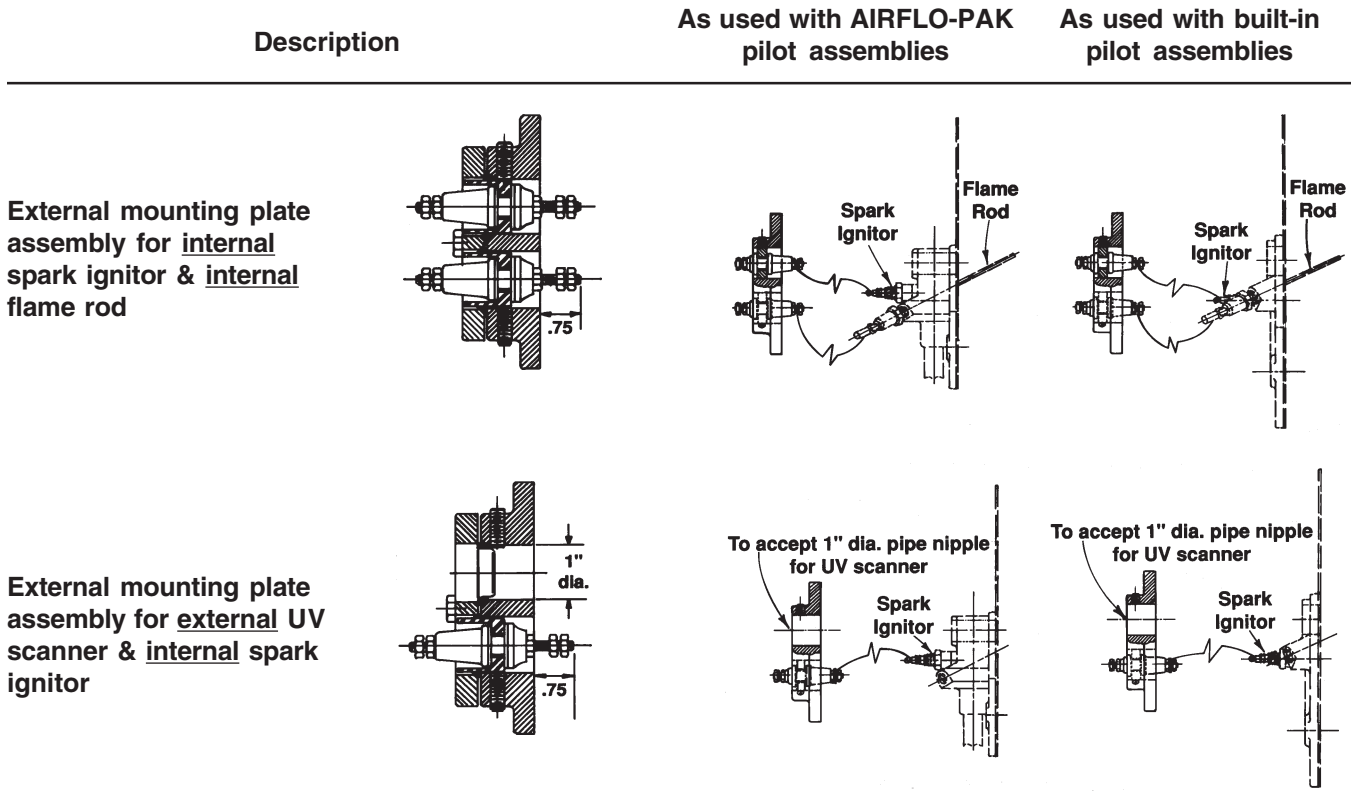

**Description**

External mounting plate assembly for external spark electrode & external UV scanner

NOTE: Order optional spark electrode sub-assembly separately

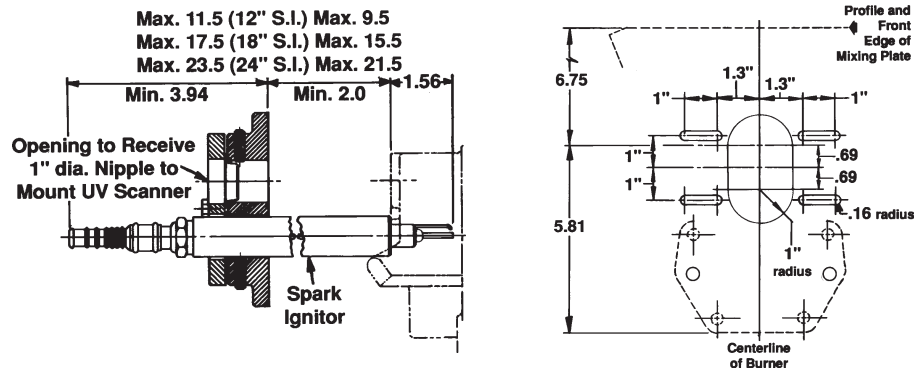

Optional external (shrouded) spark electrode for above

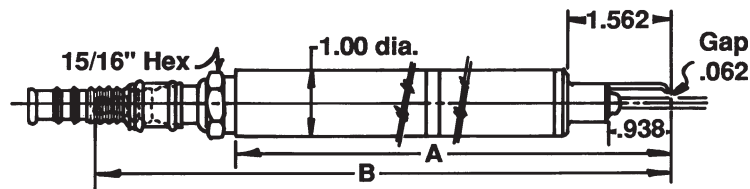

External electrode	12"	18"	24"	36"
Dimension "A"	12	18	24	34.437
Dimension "B"	13.781	19.781	25.781	36.170



## Accessory Dimensions (in inches)

### Profile Plate Bracket

Provides support for profile within closed burner loop. On some applications, it may be necessary to restrict air flow between adjacent burner rows to achieve design operating velocities. This is done by installing customer-fabricated profile plates on profile mounting bracket(s). See **sketch 1** below for use on square openings (formed by adjacent cross-sections of burner). **Sketch 2** applies to rectangular opening.

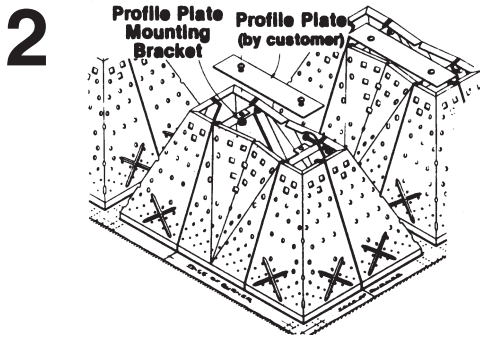
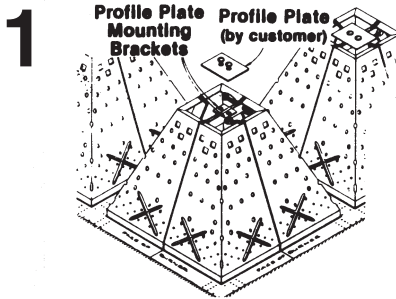
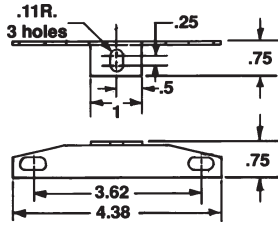

### Universal support bracket

Normally used in pairs as shown below. Mount to burner assembly at any joint between sections. Two versions available: zinc plated carbon steel for maximum inlet temperature up to 750°F (399°C) or #304SS for maximum inlet temperature up to 1600°F (871°C).

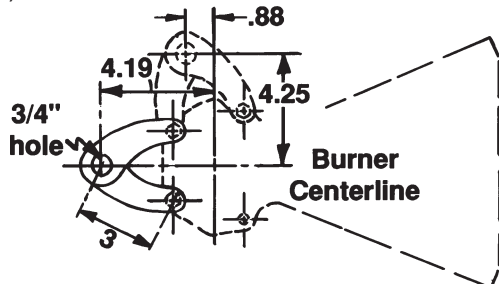

### Division plate

Provides isolation of burner feed(s) where desirable.



### Optional electrode cover

Protects porcelain insulator and electrical connection from dirt and moisture. May be used for ambient temperatures up to 450°F (232°C).



### 14mm Spark Ignitor

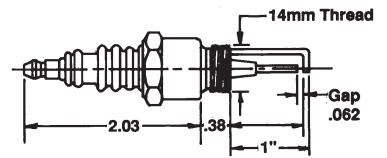

### Spark Electrode

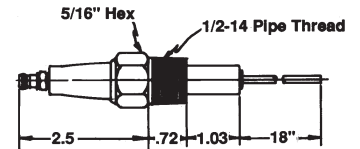

### Flame rod identification

For those COMBUSTIFUME® Burners using flame rods, most applications are covered by one of two sizes (specific number depends on nominal length "N" of rod extension). These may need cut to dimension "L" specified in tables on page 9908A before use in your particular application.

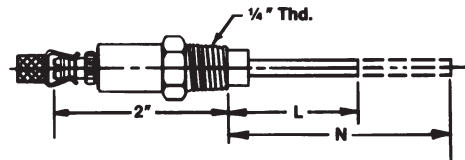

N
7-1/2"
24"

# Component Identification

## INCINO-PAK® Burner Back Inlet Feed Section

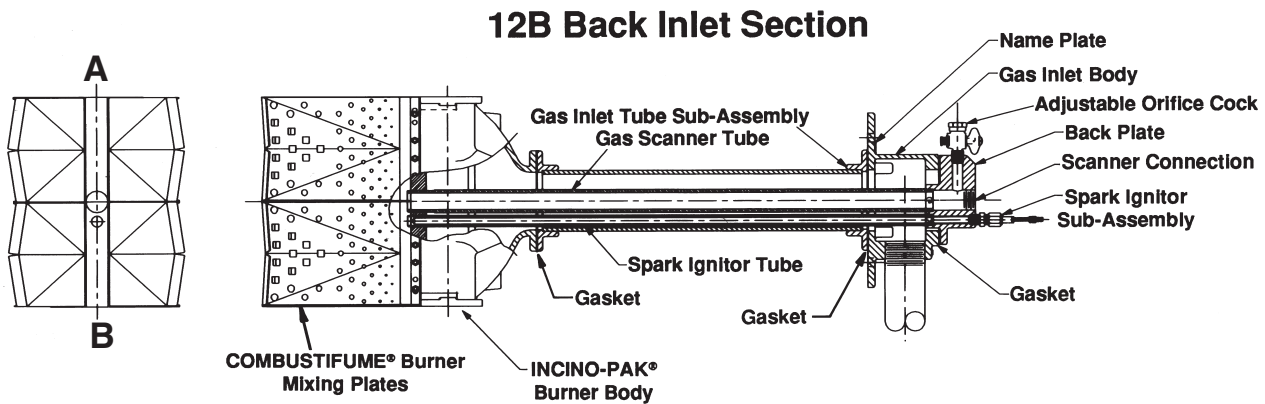
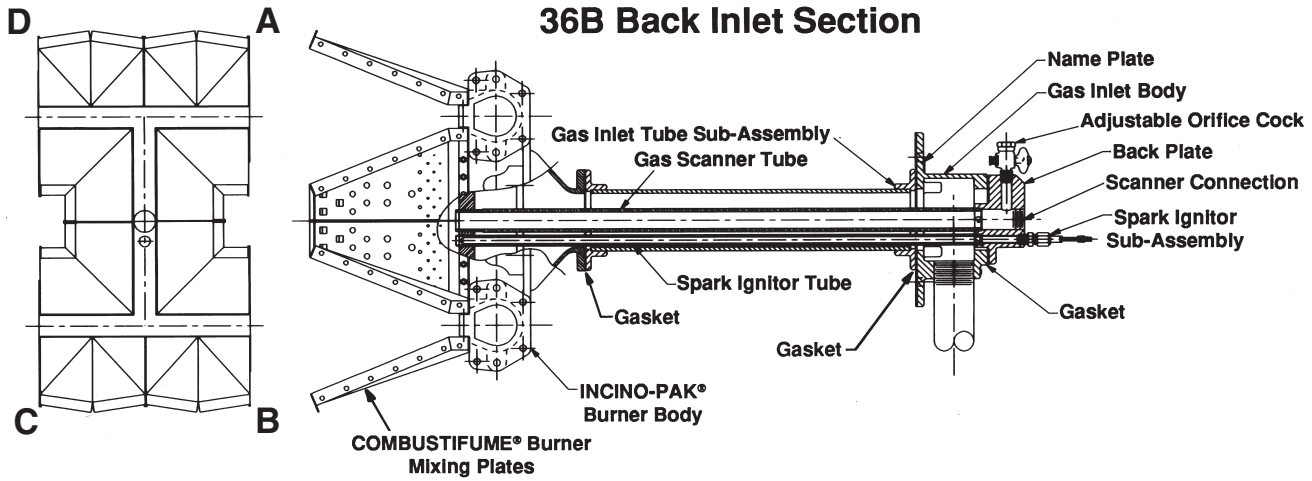

Nameplate located on  
COMBUSTIFUME® Burner body

Nameplate located on  
INCINO-PAK® Burner gas inlet body

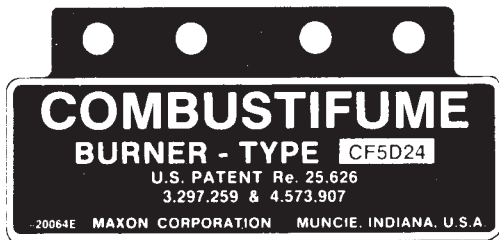

# Component Identification

## COMBUSTIFUME® Line Burners

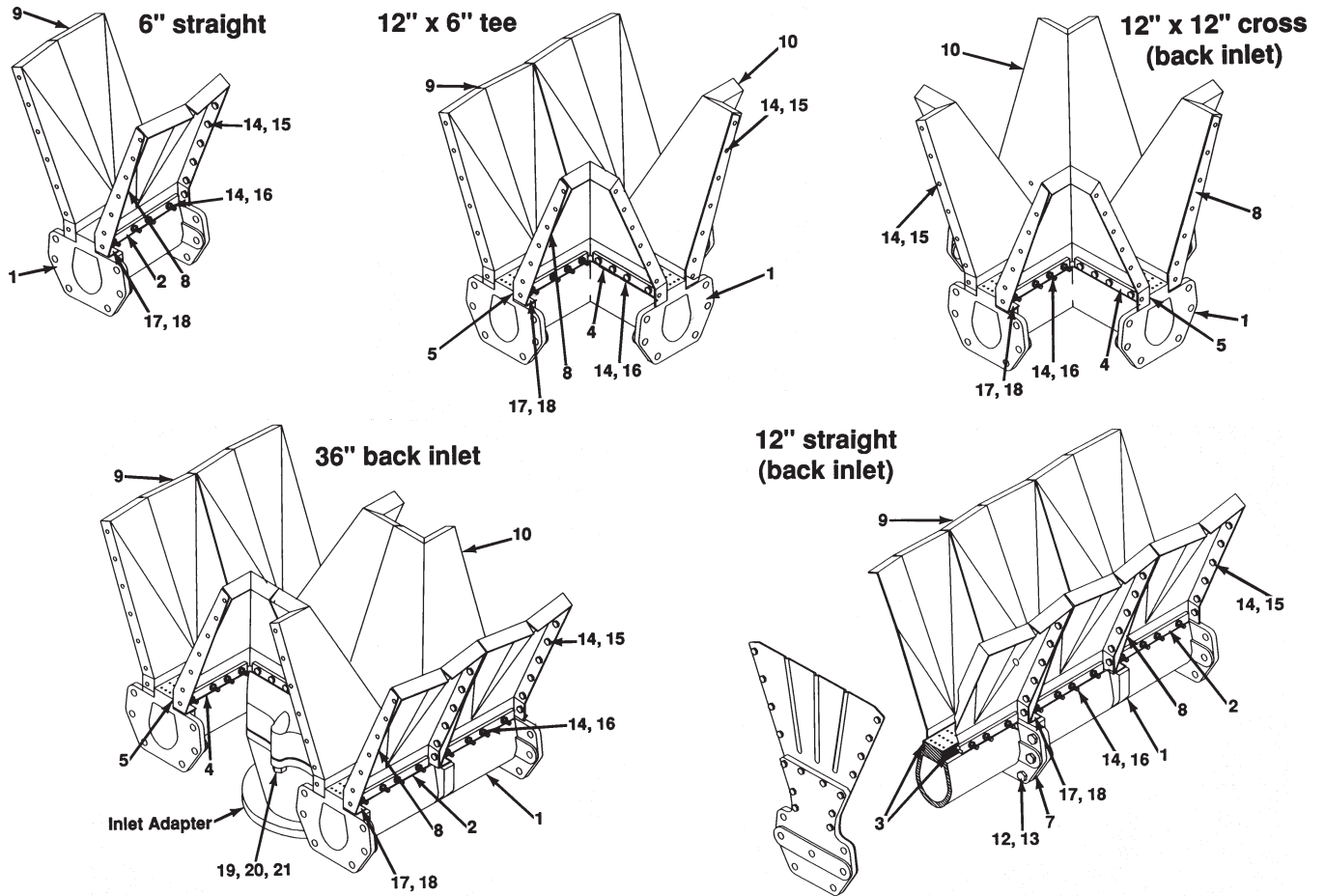

**To order replacement parts:**

1. Identify specific COMBUSTIFUME® series/type from burner assembly information plate pictured on page 5720.
2. Provide sketch of burner arrangement, as viewed from back (or casting side) of assembly. For example:

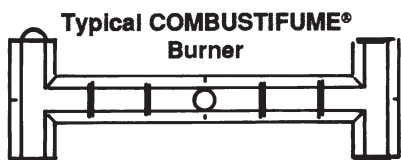

3. Specify quantity of each replacement item required from table at right.

Item Number	Part Description
1	Burner body
2	Back up bar (straight)
3	Gasket, body (straight)
4	Back up bar (inside)
5	Gasket, inside
6	Back up bar (outside)
7	Burner body gasket (between joints)
8	Support bracket gasket 18 GA
9	6" mixing plate
10	Corner mixing plate
12	M10 - 1.5 x 45 hex head cap screw
13	M10 - 1.5 finished hex nut
14	#10 -24 FLEX-LOK hex nut
15	#10 -24 x 1/2" indented hex head machine screw
16	#10 -24 x 2-1/4" indented hex head machine screw
17	Washer
18	#10 -24 x 3/8" indented hex head machine screw
19	M10 - 1.5 hex nut finished
20	M10 - 1.5 x 35 hex head cap screw
21	1/4" -20 x 3/4" hex head cap screw

# Notes