

# ECO-STAR II

Packaged Low NOx Multi-Fuel Burner

ESII-1  
Edition 05-08

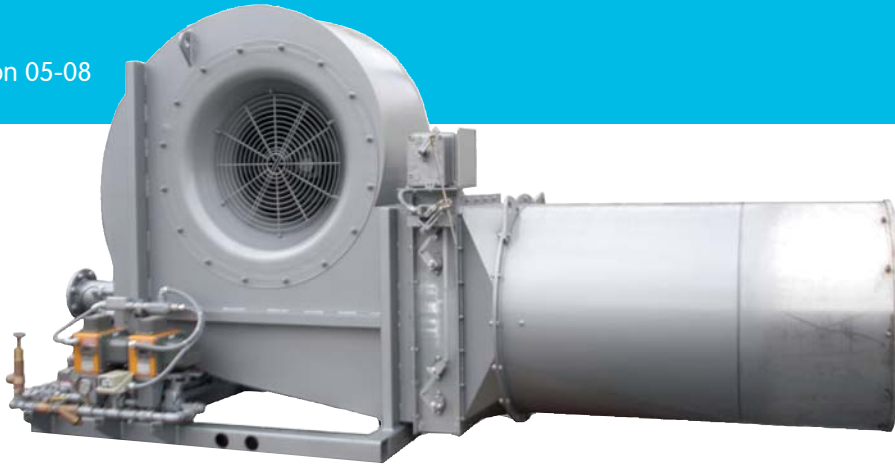

Hauck, a product brand  
of the Elster Group



- Compact packaged design
- Easy installation, setup and maintenance
- Burner skid-mounted fuel manifolds
- Fast mixing/burning with compact flames
- Fuel efficient multi-fuel capability: natural gas, No. 2 - No. 6 fuel oils, liquid propane, landfill gas
- Improved recycled and heavy oil atomization
- 1800 rpm impellers for low wear
- Single pilot/main flame scanner
- Variable flame shaping
- Low CO, NOx and VOC emissions
- Valves can be characterized to maintain air/fuel ratio over entire operating range
- Total air design

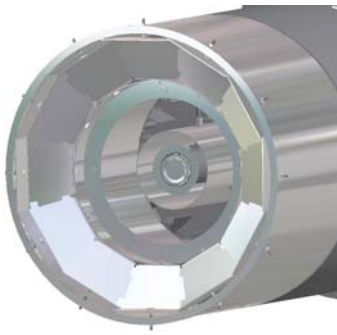

With the same excellent burner stability as its EcoStar predecessors, the Eco-Star II offers design and performance advantages in a service accessible profile and compact, easy to install package. The burner supports a wide variety of liquid and gaseous fuels offering flexibility for optimizing fuel costs. Low pressure atomization is used for light fuel oil or LP with high pressure compressed air atomization available for heavy fuel oils or high elevation installations. Emissions of NOx, CO and VOCs are minimized with proven, state of the art technologies.

Available in sizes ranging from a nominal 75 to 200 million Btu/hr (19,800 to 52, 900 kW), the Eco-Star II is ready to meet your production needs. The standard design can be applied to applications up to 1500°F (815°C).

The Eco- Star II is designed to be a uniquely reliable low emission burner.

The Eco-Star II precisely controls air/fuel ratio over its entire operating range with a 100% total air design. This proven technology reduces inefficient excess air, lowering fuel costs and improving production. The burner's compact skid-mounted package adapts easily to most installations.

The burner's wide range of flame shaping ability allows the flame to be adapted to specific process requirements. All combustion is completed within the recommended combustion zone, further reducing emissions by eliminating flame quenching from process materials.



**Eco-Star II 150 High Fire @ 160 MM Btu/hr (42,300 kW) - No. 2 Fuel Oil Low Pressure @ Low Spin Setting**

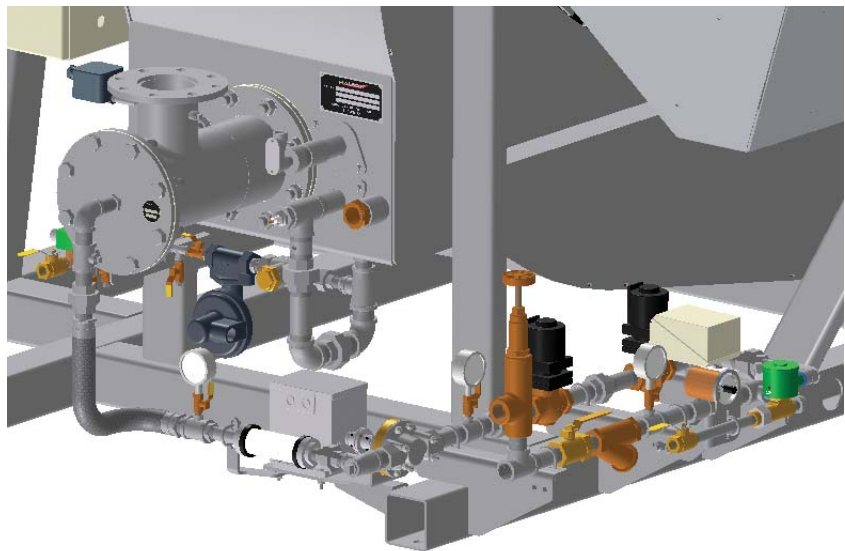

The Eco-Star II's sealed-in construction, coupled with its high efficiency aerodynamic design, significantly reduces operational noise. As with all Hauck products, the Eco-Star II is backed by our internationally recognized service department and our more than 50 years of experience as a leader and partner to the asphalt industry.

For additional information on this product, visit our website at:

[www.hauckburner.com](http://www.hauckburner.com)

Hauck Manufacturing Company  
POB 90  
Lebanon, PA 17042

T +1 717-272-3051  
F +1 717-273-9882  
[info@hauckburner.com](mailto:info@hauckburner.com)

Hauck, a product brand  
of the Elster Group



Copyright © 2008 Elster Group