

ImmersoJet

Burners

Model IJ-8

Version 2

Parameter	Blower Size	
Blower Type	Packaged Blower	Remote Blower
Maximum Input Btu/h (kW)	3,500,000 (1024.8)	4,800,000 (1405.5)
Minimum Input Btu/h (kW)	300,000 (87.9)	300,000 (87.9)
Air Inlet Pressure "w.c. (mbar) @ Max Input Air pressure at burner inlet (Tap "A")	16.5 (41.1)	19.5 (48.6)
Blower Motor Hp (kW)	3.0 (2.2)	As Specified
Main Gas Pressure Supplied to Regulator "w.c. (mbar)	21 - 125 (52.3 - 311.4)	28 - 128 (69.8 - 318.8)
Backpressure "w.c. (mbar)	2.0 (4.9)	3.8 (9.5)
Weight lbs (kg)	290 (131)	185 (84)
CO Emissions (ppm)	<100	<100
Piping	NPT or BSP	
Flame Detection	Flamerod or UV Scanner	
Fuel <i>For any other mixed gas, contact Eclipse.</i>	Natural Gas, Propane, Butane ^{1, 2}	
Approvals		

¹ Different fuels require different nozzles and orifices.

² See Design Guide 110 for more information about typical fuel composition and properties.

- All information is based on laboratory testing with a tube effective length of 21.6 feet (6.58 m). Different tube sizes and conditions may affect the data.
- All information is based on standard tube design. Changes in the tube will alter performance and pressures.
- All inputs based upon gross calorific values (HHV).
- Eclipse reserves the right to change the construction and/or configuration of our products at any time without being obliged to adjust earlier supplies accordingly.
- Plumbing of air and gas will affect accuracy of orifice readings. All information is based on generally acceptable air and gas piping practices.
- Packaged blower performance data based on 60 Hz..

Performance Graphs

Typical Operational Curve & Ignition Zone (Natural Gas, Propane & Butane)

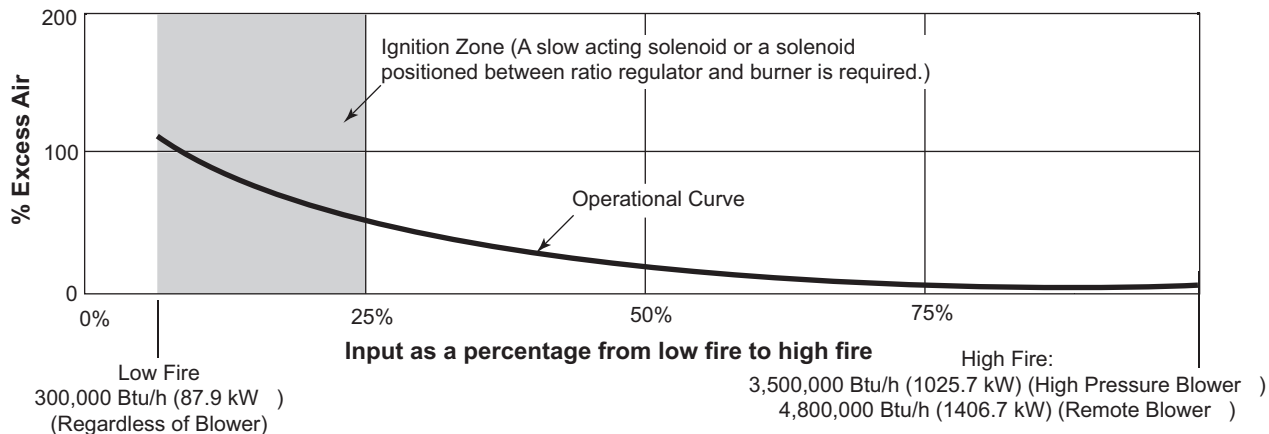

Gas Orifice Δp vs. Input
Measured from Tap "B" to Tap "D"

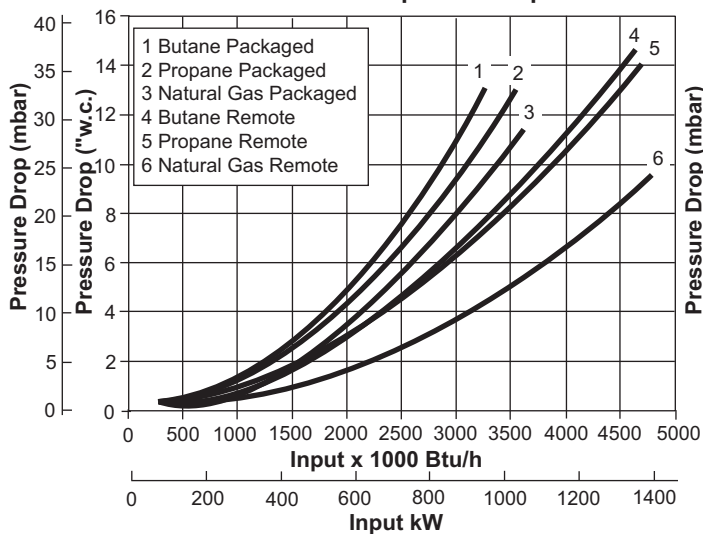

Air Orifice Δp vs. Input
Measured from Tap "A" to Tap "C"

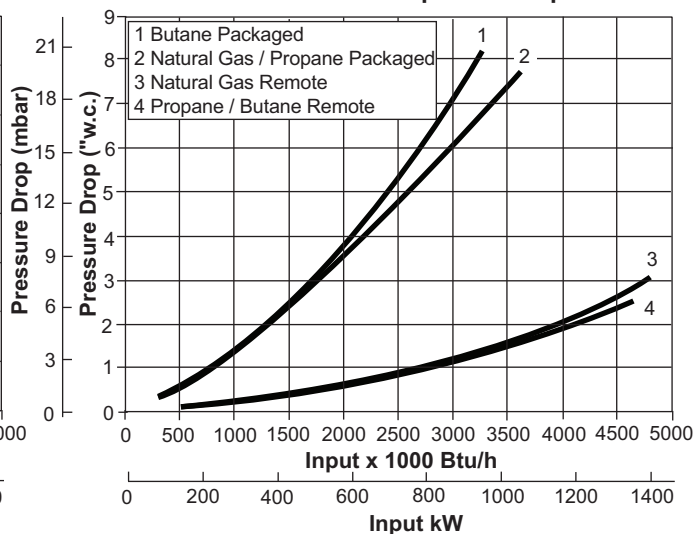

Loading Line Pressure vs. Input
Measured at Tap "A"

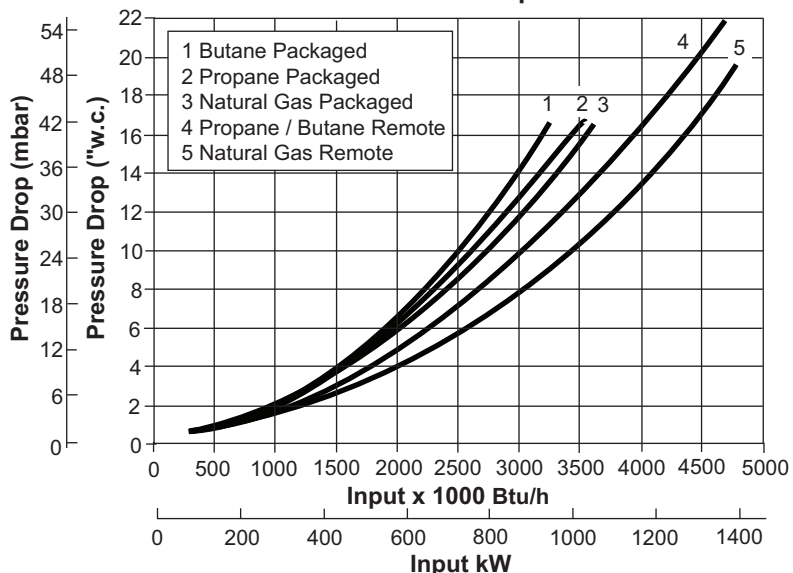

Dimensions & Specifications

Dimensions in mm (inches)

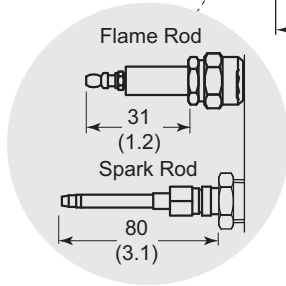
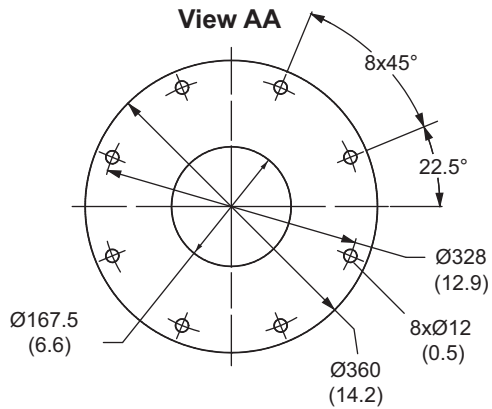
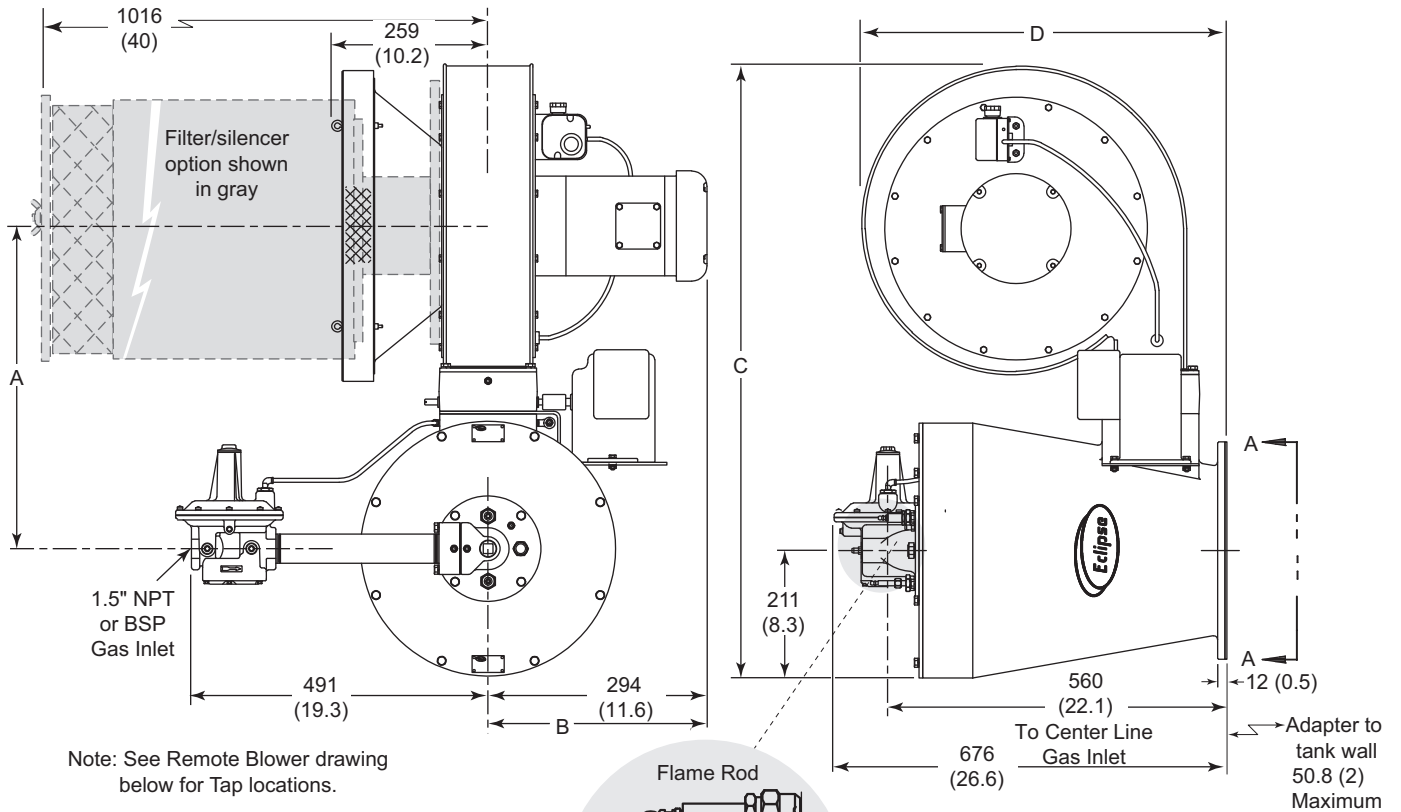

	A	B		C	D
		60 Hz	50 Hz		
High Pressure Blower	533 (20.98)	362 (14.3)	320 (12.6)	1013 (39.9)	604 (23.8)

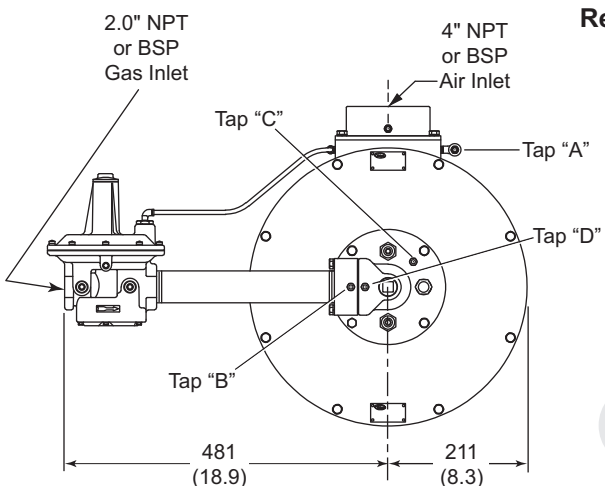

Remote Blower

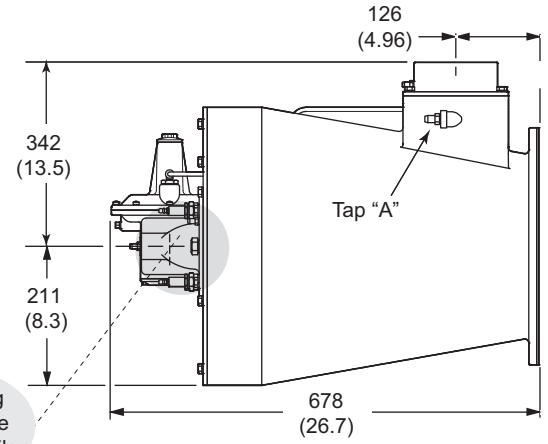

See above drawing for Spark and Flame Rod dimension details

