

**D****GB****F****I****DUNGS**<sup>®</sup>  
Combustion Controls

<b>EU-Konformitäts- erklärung</b>	<b>EU-Declaration of conformity</b>	<b>Déclaration de conformité EU</b>	<b>Dichiarazione di conformità EU</b>
<b>Gebrauchs- anleitung</b>	<b>Instructions</b>	<b>Notice d'utilisation</b>	<b>Istruzioni di esercizio e di montaggio</b>
<b>MBC-65... / MBC-120...</b>			
<b>GasMultiBloc<sup>®</sup> einstufige Betriebsweise</b>	<b>GasMultiBloc<sup>®</sup> single stage mode</b>	<b>GasMultiBloc<sup>®</sup> gaz à une allure</b>	<b>GasMultiBloc<sup>®</sup> monostadio</b>
<b>Nennweiten Nominal diameters Diamètres nominaux Diametri nominali</b>		<b>Rp <math>\frac{3}{8}</math> - Rp <math>\frac{3}{4}</math></b>	

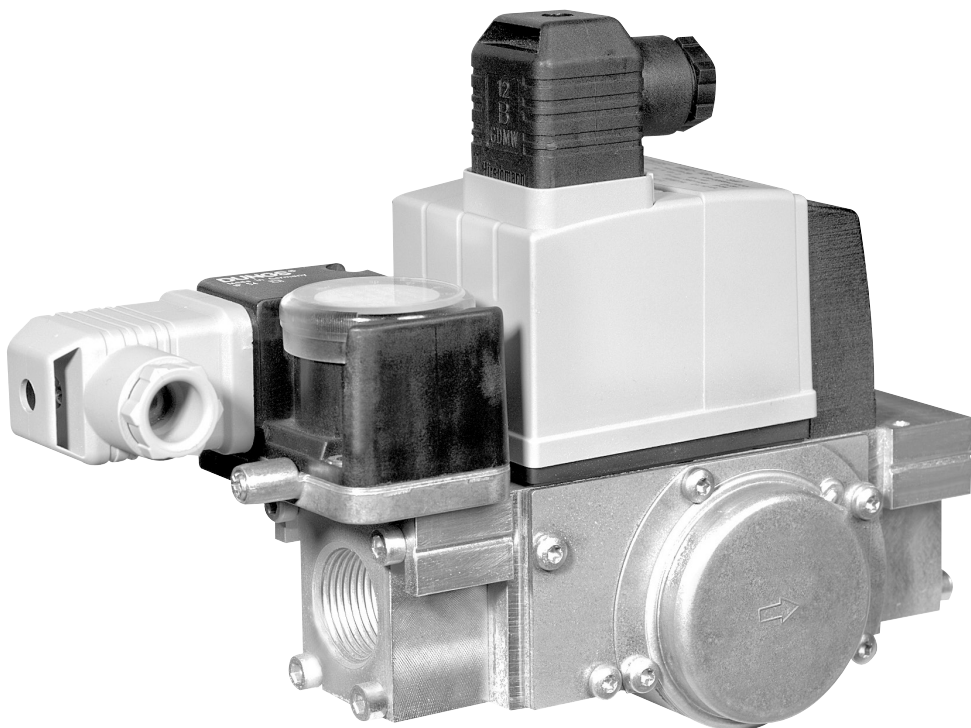

**MBC-65... / MBC-120...**  
**# 247 652**



**EU-Konformitäts-  
erklärung**

**EU Declaration of  
conformity**

**Déclaration de  
conformité EU**

**Dichiarazione di  
conformità EU**

<b>Produkt / Product Produit / Prodotto</b>	<b>MBC-65... MBC-120...</b>	<b>GasMultiBloc® einstufige Betriebsweise GasMultiBloc®, single stage mode GasMultiBloc® gaz à une allure GasMultiBloc® monostadio</b>	
<b>Hersteller / Manufacturer Fabricant / Produttore</b>	<b>Karl Dungs GmbH &amp; Co. KG Karl-Dungs-Platz 1 D-73660 Urbach, Germany</b>		
bescheinigt hiermit, dass die in dieser Übersicht genannten Produkte einer <b>EU-Baumusterprüfung</b> unterzogen wurden und die wesentlichen Sicherheitsanforderungen der:	certifies herewith that the products named in this overview were subjected to an <b>EU Prototype Test</b> and meet the essential safety requirements:	certifie par la présente que le produit mentionné dans cette vue d'ensemble a été soumis à un <b>examen de type de l'UE</b> et qu'il est conforme aux exigences en matières de sécurité des dernières versions en vigueur de :	Con la presente si certifica che i prodotti citati in questa panoramica sono stati sottoposti a una prova di <b>omologazione UE</b> e che i requisiti di sicurezza essenziali:
<b>EU-Gasgeräteverordnung 2016/426</b>	<b>EU Gas Equipment Regulation 2016/426</b>	<b>l'ordonnance de l'UE relative aux appareils au gaz 2016/426</b>	<b>regolamento UE sugli apparecchi a gas 2016/426</b>
<b>EU-Druckgeräterichtlinie 2014/68</b>	<b>EU Pressure Equipment Directive 2014/68</b>	<b>à la directive UE « Équipements sous pression » 2014/68</b>	<b>direttiva UE sulle attrezzature a pressione 2014/68</b>
in der gültigen Fassung erfüllen.	as amended.		sono soddisfatti nella versione valida.
Bei einer von uns nicht freigegebenen Änderung des Gerätes verliert diese Erklärung ihre Gültigkeit.	In the event of an alteration of the equipment not approved by us this declaration loses its validity.	Ce communiqué n'est plus valable si nous effectuons une modification libre de l'appareil.	In caso di modifica dell'apparecchio non ammessa, questa dichiarazione perde di validità.
<b>Prüfgrundlage der EU-Baumusterprüfung Specified requirements of the EU Prototype Test Base d'essai de l'examen de type de l'UE Criteri di prova dell'omologazione UE</b>	<b>EN 161 ISO 23551-8</b>		
<b>Gültigkeitsdauer/Bescheinigung Term of validity/attestation Validité/certificat Durata della validità/Attestazione</b>	<b>2023-05-26 CE0036</b>	<b>2028-04-09 CE-0123CT1023</b>	
<b>Notifizierte Stelle Notified Body Organisme notifié Organismo notificato</b>	<b>2014/68/EU TÜV SÜD Industrie Service GmbH Westendstraße 199 D-80686 München Germany Notified Body number: 0036</b>	<b>(EU) 2016/426 TÜV SÜD Product Service GmbH Zertifizierstellen Ridlerstraße 65 D-80339 München Germany Notified Body number: 0123</b>	
<b>Überwachung des QS-Systems Monitoring of the QA system Contrôle du système d'assurance qualité Monitoraggio del sistema QS</b>	<b>Gewähltes Konformitätsverfahren Modul B+D Conformity process adopted: Module B+D Procédure de conformité sélectionnée : module B+D Procedura di conformità selezionata: modulo B+D</b>		

Dr.-Ing. Karl-Günther Dalsaß,  
Geschäftsführer / Chief Operating Officer  
Directeur / Amministratore  
Urbach, 2018-04-21



Product Service

# EU-Baumusterprüfbescheinigung

Nr. C5A 18 04 22629 018

**Zertifikatsinhaber:** **Karl Dungs GmbH & Co. KG**

Karl-Dungs-Platz 1  
73660 Urbach  
DEUTSCHLAND

**Produkt:** **Ausrüstungen (Gas)  
Mehrfachstellgerät**

**Modell(e):** **Baureihe MBC-65  
Baureihe MBC-120**

**Kenndaten:** Gültig ab 21.04.2018  
PIN CE-0123CT1023

alle weiteren Kenndaten siehe Anhang

**Geprüft nach:** DIN EN 126:2012  
DIN EN 161:2013  
DIN EN 88-1:2016  
DIN EN 13611:2011  
ISO 23551-8:2016  
ISO 23551-1:2012  
ISO 23551-2:2006  
ISO 23550:2011

Die Zertifizierstelle von TÜV SÜD Product Service GmbH bestätigt gemäß Anhang III (Modul B) die Übereinstimmung des bezeichneten Produktes mit den wesentlichen Anforderungen gemäß Anhang I der Verordnung (EU) 2016/426 über Geräte zur Verbrennung gasförmiger Brennstoffe. Prüfgrundlage ist ausschließlich das zur Prüfung und Zertifizierung vorgestellte Prüfmuster sowie dessen technische Dokumentation. Umseitige Hinweise sind zu beachten.

**Prüfbericht Nr.:** V-M 1609-00/18

**Gültig bis:** 2028-04-09



**Datum,** 2018-04-10 (Norbert Hörmann)

TÜV SÜD Product Service GmbH ist notifizierte Stelle gemäß der Verordnung (EU) 2016/426 über Geräte zur Verbrennung gasförmiger Brennstoffe mit der Kennnummer 0123.

Seite 1 von 5



Product Service

# EU-Type Examination Certificate

No. C5A 18 04 22629 018

**Holder of Certificate:** **Karl Dungs GmbH & Co. KG**

Karl-Dungs-Platz 1  
73660 Urbach  
GERMANY

**Product:** **Fittings (Gas)**  
**Multifunctional control**

**Model(s):** **Series MBC-65**  
**Series MBC-120**

**Parameters:** Valid from 2018-04-21  
PIN CE-0123CT1023

for further information see annex

**Tested according to:** DIN EN 126:2012  
DIN EN 161:2013  
DIN EN 88-1:2016  
DIN EN 13611:2011  
ISO 23551-8:2016  
ISO 23551-1:2012  
ISO 23551-2:2006  
ISO 23550:2011

The Certification Body of TÜV SÜD Product Service GmbH confirms according to Annex III (Module B) that the listed product complies with the relevant provisions according to Annex I of Regulation (EU) 2016/426 on appliances burning gaseous fuels. It refers only to the sample submitted for testing and certification and on its technical documentation. See also notes overleaf.

**Test report no.:** V-M 1609-00/18

**Valid until:** 2028-04-09



**Date,** 2018-04-10

(Norbert Hörmann)

TÜV SÜD Product Service GmbH is Notified Body according to Regulation (EU) 2016/426 on appliances burning gaseous fuels with identification No. 0123.

Page 1 of 5



## Betriebs- und Montageanleitung

### GasMultiBloc® einstufige Betriebsweise

Typ MBC-65...  
Typ MBC-120...  
Nennweiten  
Rp 3/8 - Rp 3/4

## Operation and assembly instructions

### GasMultiBloc®, single-stage mode

Type MBC-65...  
Type MBC-120...  
Nominal diameters  
Rp 3/8 - Rp 3/4

## Notice d'emploi et de montage

### MultiBloc® gaz à une allure

Typ MBC-65...  
Typ MBC-120...  
Diamètres nominaux  
Rp 3/8 - Rp 3/4

## Istruzioni di esercizio e di montaggio

### GasMultiBloc® monostadio

Tipo MBC-65...  
Tipo MBC-120...  
Diametri nominali  
Rp 3/8 - Rp 3/4

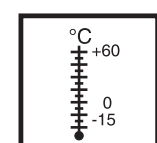
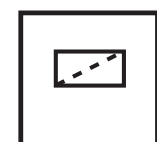
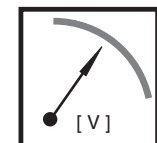
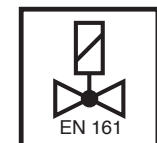
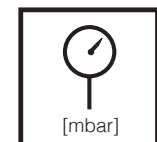
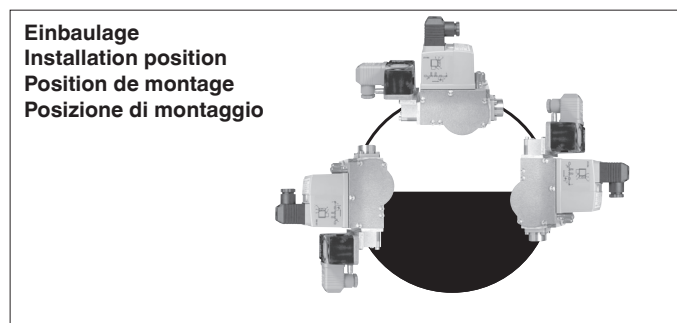

Max. Betriebsdruck / Max. operating pressure / Pression de service maxi. / Max. pressione di esercizio

MBC-65:  $p_{max} = 200 \text{ mbar (20 kPa)}$   
MBC-65-N./S00/S02:  $p_{max} = 65 \text{ mbar (6,5 kPa)}$   
MBC-120:  $p_{max} = 360 \text{ mbar (36 kPa)}$   
MBC-120-N./S00/S02:  $p_{max} = 100 \text{ mbar (10 kPa)}$

V1+V2 Klasse A, Gruppe 2  
V1+V2 class A, group 2  
V1+V2 classe A, groupe 2  
V1+V2 Classe A, gruppo 2  
nach / acc. / selon / a norme  
EN 161

$U_n \sim (\text{AC}) 230 \text{ V} +10 \% / -15 \%$   
oder/or/ou/o  
 $\sim (\text{AC}) 110 \text{ V}, =(\text{DC}) 24 \text{ V}$   
MBC-65: 24 VA, MBC-120: 24 VA  
Einschaltdauer/Switch-on-duration/  
Durée de mise en circuit / Durata  
inserzione 100 %

Klasse C  
Class C  
Classe C  
Classe C  
nach / acc. / selon / a norme  
EN 88

Feinsieb 120  $\mu\text{m}$   
microfilter 120  $\mu\text{m}$   
Filtre fin 120  $\mu\text{m}$   
Filtro a rete 120  $\mu\text{m}$

Umgebungstemperatur  
Ambient temperature  
Température ambiante  
Temperatura ambiente  
-15 °C ... +60 °C

In Flüssiggasanlagen den MBC-... nicht unter 0 °C betreiben. Nur für gasförmiges Flüssiggas geeignet, flüssige Kohlenwasserstoffe zerstören die Dichtwerkstoffe. Do not operate the MB-... below 0 °C in liquid gas systems. Do not operate MBC-... below 0 °C in liquid gas systems. Only suitable for gaseous liquid gas; liquid hydrocarbons destroy the sealing materials.

Le MBC-... ne doit pas être utilisé en dessous de 0 °C dans les installations à GPL. Convient uniquement au GPL en phase gazeuse, les hydrocarbures liquides détériorent les matériaux d'étanchéité.  
Negli impianti a gas liquido, non si dovrà far funzionare il Multibloc MBC-... al di sotto di 0 °C. Esso è adatto soltanto per gas liquido gassoso, gli idrocarburi liquidi distruggono i materiali di tenuta.

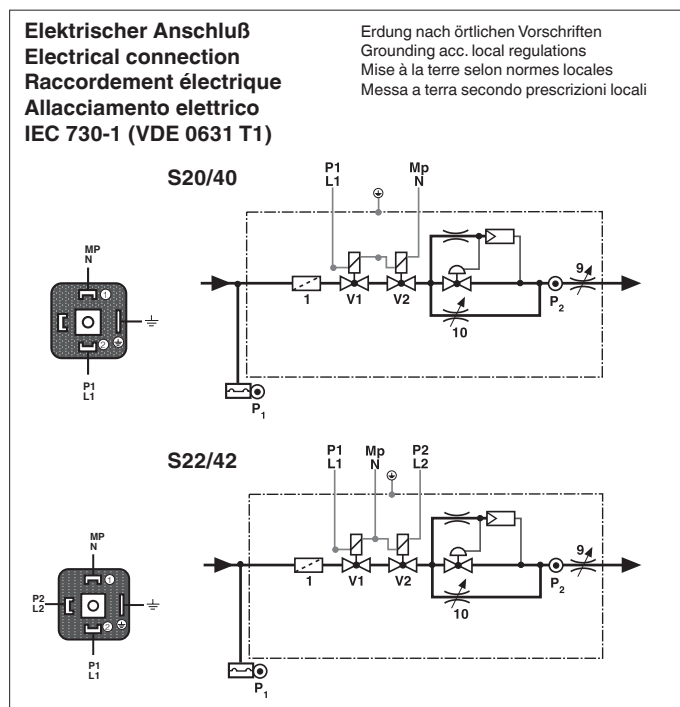

Elektrischer Anschluß  
Electrical connection  
Raccordement électrique  
Allacciamento elettrico  
IEC 730-1 (VDE 0631 T1)

Erdung nach örtlichen Vorschriften  
Grounding acc. local regulations  
Mise à la terre selon normes locales  
Messa a terra secondo prescrizioni locali

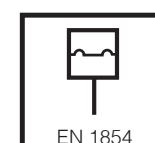
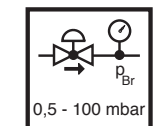
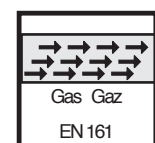

Schutzart  
Degree of protection  
Protection  
Protezione  
IP 54 nach / acc. / selon / a norme  
IEC 529 (DIN 40 050)

Familie 1 + 2 + 3  
Family 1 + 2 + 3  
Famille 1 + 2 + 3  
Famiglia 1 + 2 + 3

Ausgangsdruckbereich  
Output pressure range  
Plage de pression de sortie  
Campo pressione in uscita

MBC...DLE-S20/S22: 3 - 15 mbar (0,3 - 1,5 kPa)  
MBC...DLE-S40/S42: 4 - 37 mbar (0,4 - 3,7 kPa)  
MBC...ND/S00/S02: 0 ± 0,2 mbar (0 ± 0,02 kPa)

Druckwächter/ Pressure Switch/  
Pressostat/ Pressostato  
Typ/Type/Type/Tipo  
GW...A5  
nach / acc. / selon / a norme  
EN 1854

**Druckabgriffe**  
**Pressure taps**  
**Prises de pression**  
**Prese di pressione**

MBC-65...

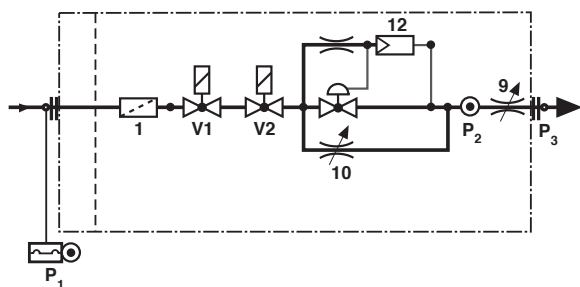

MBC-120...

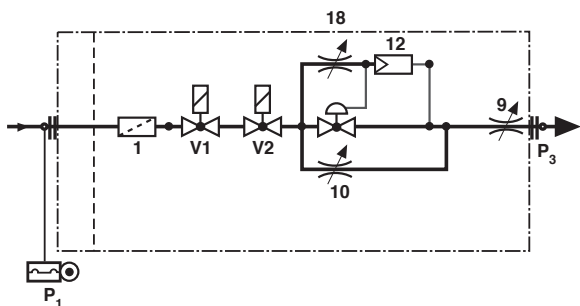

- 1 Feinsieb / Microfilter / Filtre fin / Filtro a rete
- 2 Eingang P1 / Inlet P1 / Entrée P1 / Entrata P1
- 3 Gehäuse / Housing / Corps / Corpo
- 4 Feder, Gasdruckregelteil / Spring, gas pressure regulator / Ressort, régulateur de pression / Molla regolatrice di pressione
- 5 Membrane, Gasdruckregelteil / Diaphragm, gas pressure regulator / Membrane, régulateur de pression / Membrana regolatrice di pressione
- 6 Deckel / Cover / Couvercle / Coperchio
- 7 Düse / Nozzle / Buse / Ugello
- 8 Ausgang P2 / Outlet P2 / Sortie P2 / Uscita P2
- 9 Hauptmengendrossel / Main flow restrictor / Réducteur de débit principal / Riduttore quantità gas principale
- 10 Startgasdrossel / Start-gas flow restrictor / Réducteur de débit de démarrage / Riduttore gas d'avvio
- 11 Dämpfer / Damper / Amortisseur / Freno
- 12 Servodruckregler / Servopressure regulator / Servo-régulateur / Servoregolatore di pressione
- 13 Einstellschraube - Hauptmenge / Adjustment screw - main flow / Vis de réglage - débit principal / Vite di regolazione quantità gas principale
- 14 Sollwertesteller - Druckregler / Reference value adjustment device - pressure regulator / Ajusteur de consigne - régulateur de pression / Regolatore di pressione valore nominale
- 15 Einstellschraube - Startmenge / Adjustment screw - start flow / Vis de réglage - débit de démarrage / Vite di regolazione quantità gas d'avvio
- 16 Magnetgehäuse V1, V2 / Solenoid housing V1, V2 / Capot bobines V1, V2 / Alloggiamento della bobina V1, V2
- 17 Elektrischer Anschluß / Electrical connection / Connecteur électrique / Allacciamento elettrico
- 18 Öffnungszeiteinstellung / Setting of opening time / Réglage del tempo di apertura / Regolazione del tempo di apertura (nur / only / seulement / solo MBC-120)

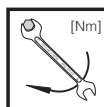
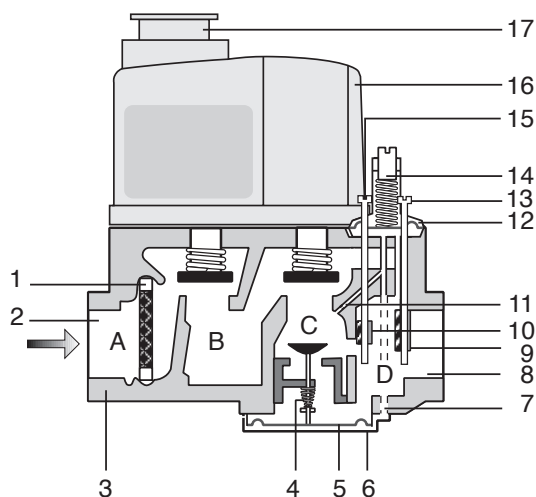

max. Drehmomente / Systemzubehör max. torque / System accessories max. couple / Accessoires du système max. coppie / Accessorio di sistema	M 3	M 4	M 5	M 6	M 8	G 1/8	G 1/4	G 1/2	G 3/4
	1,2 Nm	2,5 Nm	5 Nm	7 Nm	15 Nm	5 Nm	7 Nm	10 Nm	15 Nm



**Geeignetes Werkzeug einsetzen!**  
**Please use proper tools!**  
**Utiliser des outils adaptés!**  
**Impiegare gli attrezzi adeguati!**

**Schrauben kreuzweise anziehen!**  
**Tighten screws crosswise!**  
**Serrer les vis en croix.**  
**Stringere le viti incrociate!**

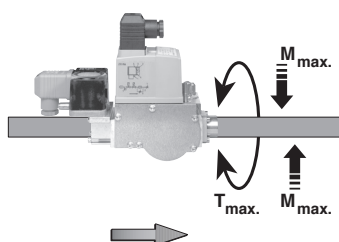

**Gerät darf nicht als Hebel benutzt werden.**  
**Do not use unit as lever.**  
**Ne pas utiliser la vanne comme un levier.**  
**L'apparecchio non deve essere usato come leva.**

DN	10	15	20	25	32	
Rp	3/8	1/2	3/4	1	1 1/4	
M <sub>max.</sub>	70	105	225	340	475	[Nm] t ≤ 10 s
T <sub>max.</sub>	35	50	85	125	160	[Nm] t ≤ 10 s

Einbaumaße  
 Installed dimensions  
 Cotes d'encombrement  
 Dimensioni  
 [mm]

Typ Typ Typ Tipo	Rp	Einbaumaße [mm] Installed dimensions Cotes d'encombrement Dimensioni					
		a	b	c	d	e	f
MBC-65	Rp 1/2	105	148	31	160	226	76
MBC-120	Rp 3/4	105	155	37	165	232	82

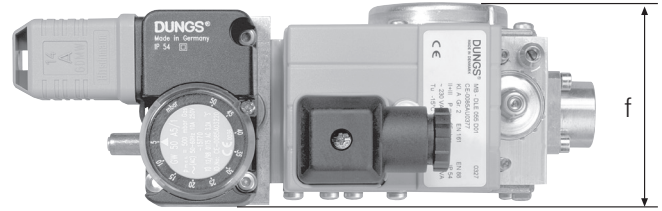
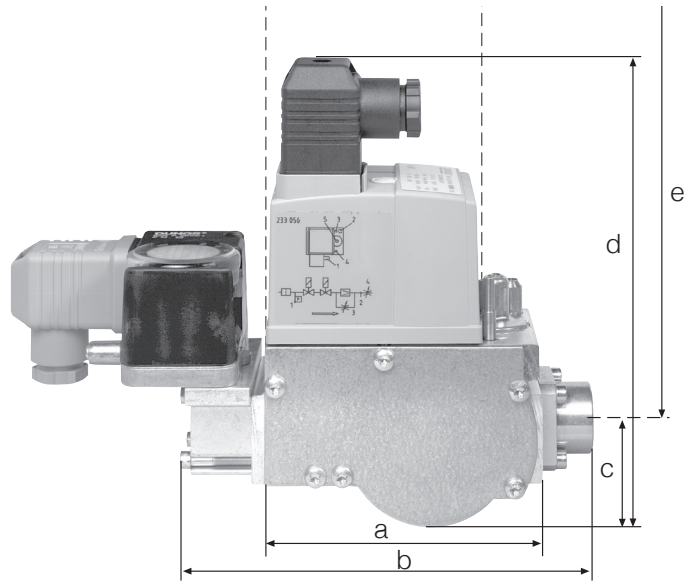

Durchfluß-Diagramm  
 Flow diagram  
 Courbe des débits  
 Diagramma di portata  
 MBC-65...

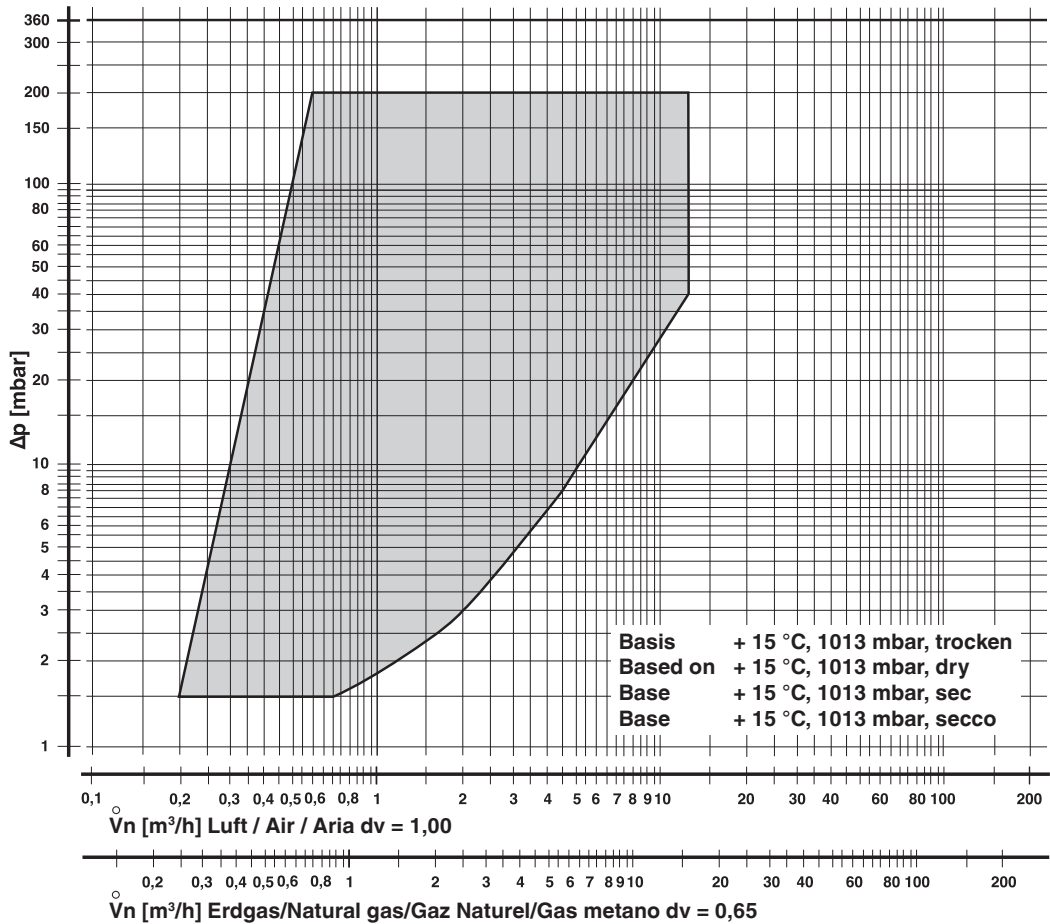

Durchfluß-Diagramm  
Flow diagram  
Courbe des débits  
Diagramma di portata  
MBC-120...

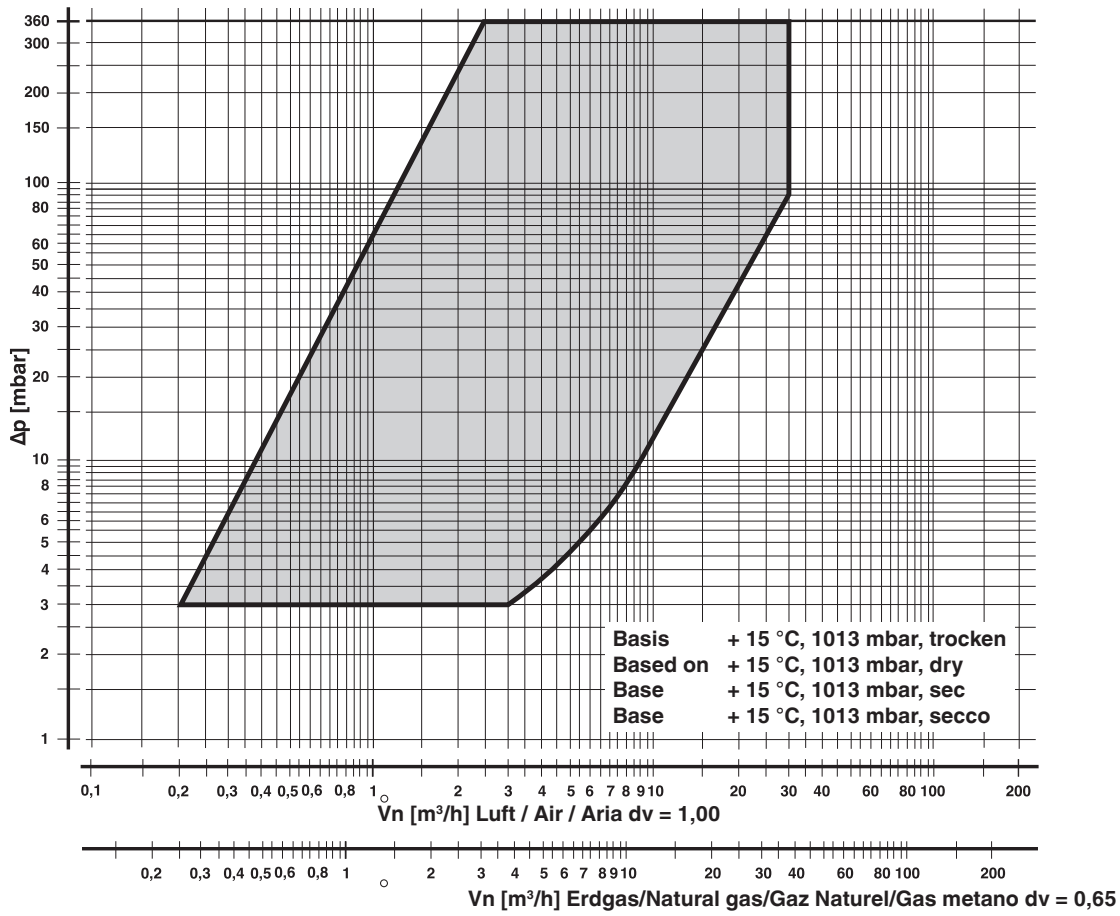

Hauptmengeneinstellung E  
Option  
MBC-65...  
MBC-120...

Main load adjustment E  
Option  
MBC-65...  
MBC-120...

Réglage principal du débit E  
Option  
MBC-65...  
MBC-120...

Regolazione portata principale E  
Opzione  
MBC-65...  
MBC-120...

MBC-65...

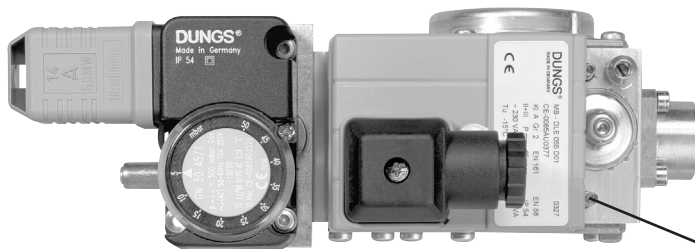

MBC-120...

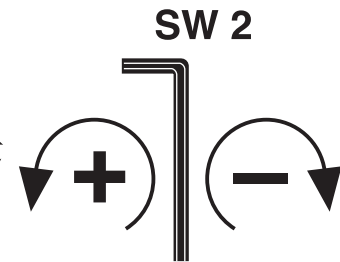

max. 0,8 Nm



MBC-65...  
MBC-120...

**Einstellung der Startgasmenge  
Option**

**Setting the start gas quantity  
Optional**

**Réglage du débit de démarrage  
Option**

**Regolazione portata gas di avvio  
Option**

- |   |  |   |   |
|---|--|---|---|
| <p>1 Schraube A im Meßstutzen lösen, Manometer anschließen.</p> <p>2 Druckregler durch Drehen der Einstellschraube B gegen den Uhrzeigersinn (max. 25 Umdrehungen) entspannen.</p> <p>3 Einstellschraube C gegen den Uhrzeigersinn auf die größte Startbelastung stellen.</p> <p>4 Gasgerät in Betrieb nehmen</p> <p>5 Startbelastung/Düsendruck durch die Einstellschraube C einstellen:</p> <p>- höherer Düsendruck gegen den Uhrzeigersinn</p> <p>- niedrigerer Düsendruck im Uhrzeigersinn</p> <p>6 Schraube A im Meßstutzen schließen.</p> <p><b>Nach Abschluß von Arbeiten am MBC-... : Dichtheitskontrolle und Funktionskontrolle durchführen.</b></p> | <p>1 Slacken screw A in measuring nozzle. Connect pressure gauge.</p> <p>2 Relieve pressure regulator by turning adjustment screw B anti-clockwise (max. 25 revolutions).</p> <p>3 Turn adjustment screw C anti-clockwise to max. starting load.</p> <p>4 Put gas appliance into operation</p> <p>5 Set starting load/nozzle pressure with adjustment screw C:</p> <p>- Higher nozzle pressure Turn screw anti-clockwise</p> <p>- Lower nozzle pressure Turn screw in the clockwise direction</p> <p>6 Close screw A in the measuring nozzle.</p> <p><b>On completion of work on the MBC-... , perform a leakage and function test.<br/>Set start gas volume</b></p> | <p>1 Desserrer la vis A de la prise de pression et raccorder le manomètre.</p> <p>2 Détendre le régulateur de pression en tournant la vis de réglage B dans le sens inverse des aiguilles d'une montre (25 tours maxi.).</p> <p>3 Tourner la vis de réglage C dans le sens inverse des aiguilles d'une montre sur la charge de démarrage maximale.</p> <p>4 Mettre l'appareil à gaz en service.</p> <p>5 Régler la charge de démarrage/pression des injecteurs à l'aide de la vis de réglage C :</p> <p>- augmenter la pression des injecteurs en tournant dans le sens inverse des aiguilles d'une montre</p> <p>- réduire la pression des injecteurs en tournant dans le sens des aiguilles d'une montre</p> <p>6 Resserrer la vis A de la prise de pression.</p> <p><b>Une fois les opérations terminées sur MBC-... , procéder à un contrôle d'étanchéité et de fonctionnement.</b></p> | <p>1 Svitare la vite A dalla presa per misuratore e collegare il manometro.</p> <p>2 Scaricare il regolatore di pressione girando la vite di regolazione B in senso antiorario (max. 25 giri).</p> <p>3 Girare la vite di regolazione C in senso antiorario al carico massimo di avviamento.</p> <p>4 Mettere in funzione l'apparecchio per gas.</p> <p>5 Regolare il carico di avvio/pressione all'ugello con la vite di regolazione C:</p> <p>- per aumentare la pressione all'ugello, girare la vite in senso antiorario</p> <p>- per ridurla, girare la vite in senso orario</p> <p>6 Riavvitare la vite di chiusura A nella presa per il misuratore.</p> <p><b>Al termine dei lavori effettuati su un MBC-... , eseguire una prova di tenuta e funzionale.<br/>Set avvio portata gas</b></p> |
|---|--|---|---|

MBC-65...  
MBC-120...

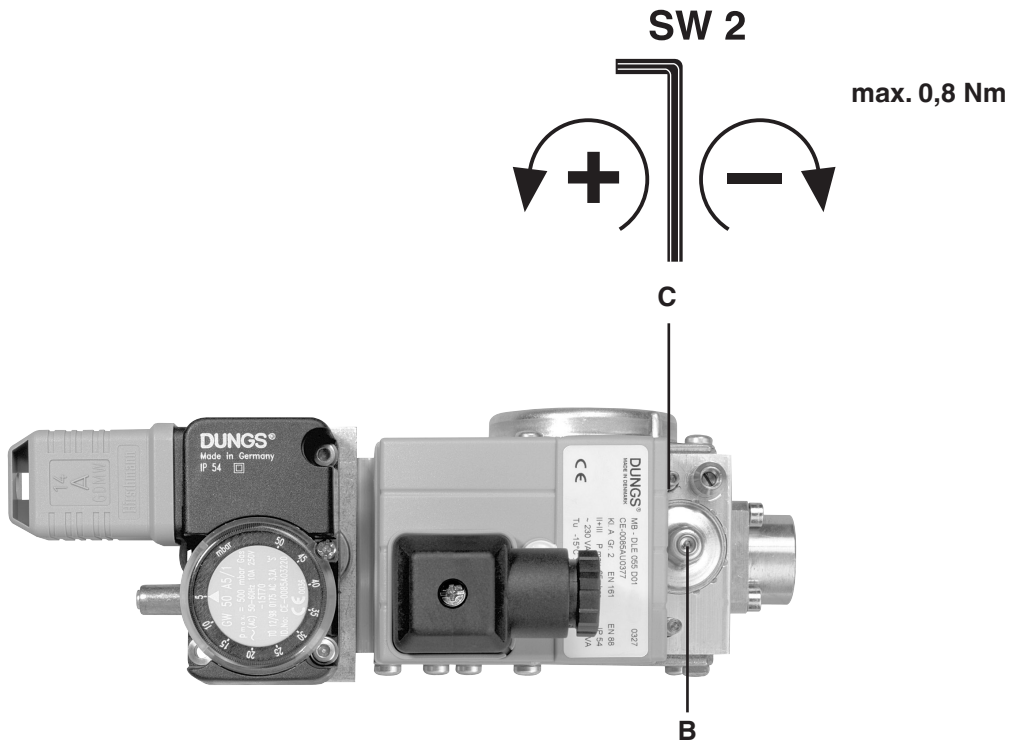

MBC-65...  
MBC-120...

**Einstellbereich der Startlast C**

Langsamer Start erfordert, daß das Hauptventil des Druckreglers beim Start geschlossen ist. Damit dies gewährleistet ist, muß eine Wartezeit von **min. 45 s** vor dem Wiederanlauf eingehalten werden.

**Starting load adjustment range C**

Slow start requires the main gas pressure regulator valve to be closed at start. To ensure this, a delay lasting **at least 45 s** is recommended before attempting a restart.

**Plage de réglage de la charge de démarrage C**

Un démarrage lent nécessite que la vanne principale du régulateur de pression soit fermée au démarrage. Afin de garantir cette condition, un temps d'attente de **45 s minimum** doit être respecté avant le redémarrage.

**Campo di regolazione carico di avvio C**

L'apertura lenta richiede che al momento della partenza la valvola principale del regolatore di pressione sia chiusa: Per assicurare ciò si deve attendere **almeno 45 secondi** prima di effettuare un nuovo avviamento.

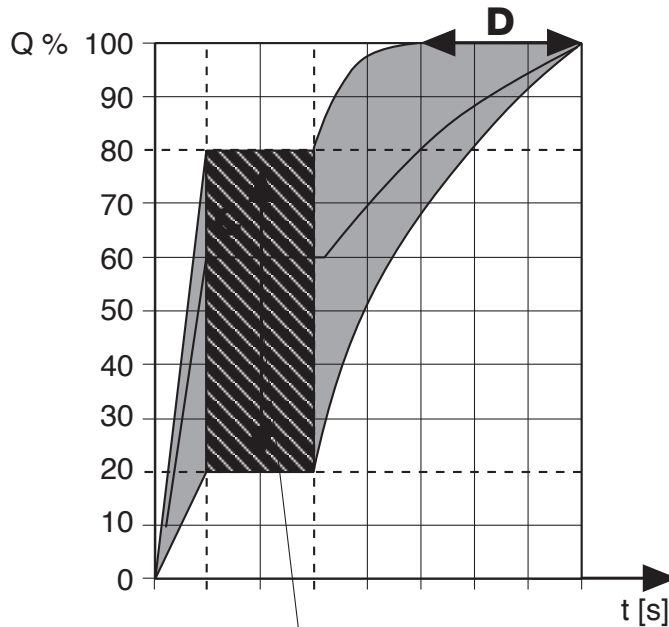

Beispiel / Example  
Exemple / Esempio  
**Startlast** =  $0,5 \times Q_{max}$   
**Starting load**  
**Charge de démarrage**  
**Carico di avvio**

MBC-65...  
Öffnungszeit fix 1 s

MBC-65...  
Openingtime 1 s

MBC-65...  
temps d'ouverture 1 s

MBC-65...  
tempo di apertura 1 s

MBC-120...  
Öffnungszeit einstellbar D  
abhängig vom Eingangsdruck

MBC-120...  
Openingtime adjustable D  
Depends on supply pressure

MBC-120...  
temps d'ouverture réglable D  
depend de la pression d'alimentation

MBC-120...  
tempo di apertura tarabile D  
dipende sulla pressione monte valvola

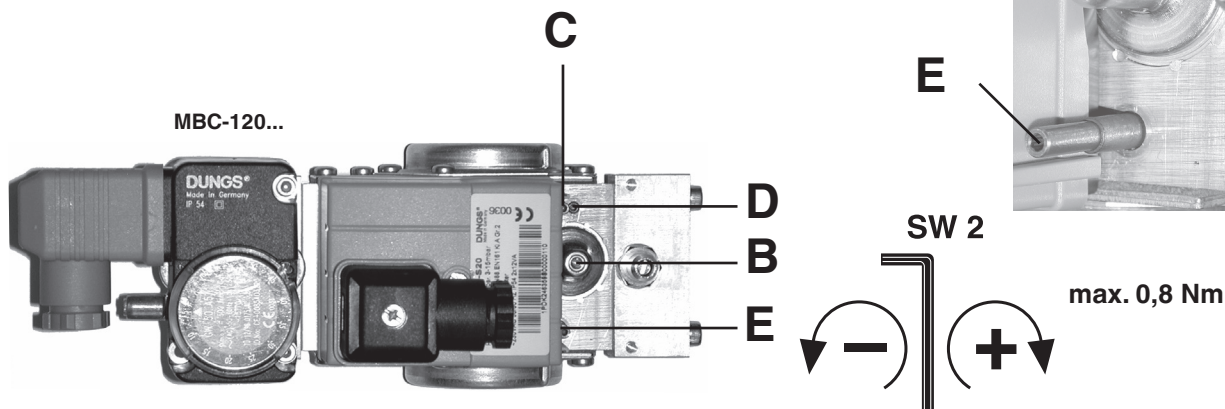

MBC-65...  
MBC-120...

**Einstellung des Gasdruckregelschalters.**

- 1 Schraube A im Meßstutzen lösen, Manometer anschließen.
- 2 Gasgerät in Betrieb nehmen
- 3 Druckregler durch die Einstellschraube B auf den Sollwert einstellen:
  - höherer Düsendruck im Uhrzeigersinn
  - niedrigerer Düsendruck gegen den Uhrzeigersinn
- 4 Schraube A im Meßstutzen schließen.

**Nach Abschluß von Arbeiten am MBC-... : Dichtheitskontrolle und Funktionskontrolle durchführen.**

**Setting the gas pressure regulator.**

- 1 Slacken screw A in the measuring nozzle and connect pressure gauge.
- 2 Put gas appliance into operation
- 3 Set pressure regulator to pilot value with Adjustment screw B:
  - Higher nozzle pressure Turn screw clockwise direction
  - Lower nozzle pressure Turn screw clockwise
- 4 Close screw A in the measuring nozzle.

**On completion of work on the MBC-... , perform a leakage and function test.**

**Réglage du régulateur de pression de gaz**

- 1 Desserrer la vis A de la prise de pression et raccorder le manomètre.
- 2 Mettre l'appareil à gaz en service.
- 3 Régler le régulateur de pression sur la valeur de consigne à l'aide de la vis de réglage B :
  - augmenter la pression des injecteurs en tournant dans le sens des aiguilles d'une montre
  - réduire la pression des injecteurs en tournant dans le sens inverse des aiguilles d'une montre
- 4 Resserrer la vis A de la prise de pression.

**Une fois les opérations terminées sur MBC-... , procéder à un contrôle d'étanchéité et de fonctionnement.**

**Regolazione del regolatore di pressione del gas**

- 1 Svitare la vite A dalla presa per il misuratore e collegare il manometro.
- 2 Mettere in funzione l'apparecchio per gas.
- 3 Regolare il regolatore di pressione al valore nominale con la vite di regolazione B:
  - per aumentare la pressione all'ugello, girare la vite in senso orario
  - per ridurla, girare la vite in senso antiorario
- 4 Riavvitare la vite di chiusura A nella presa per il misuratore.

**Al termine dei lavori effettuati su un MBC-... , eseguire una prova di tenuta e funzionale.**

MBC-65...



MBC-120...

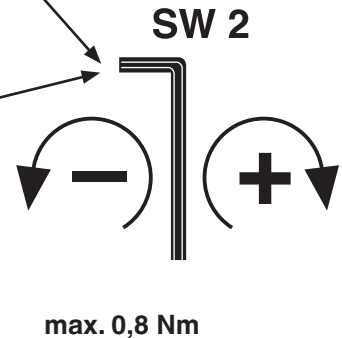



Arbeiten am MBC dürfen nur von Fachpersonal durchgeführt werden.

Only trained personnel may perform work on the MBC.

Seules des personnes qualifiées sont autorisées à intervenir sur le MBC.

Qualsiasi operazione effettuata sugli MBC deve essere effettuata soltanto da personale competente.



Flanschflächen schützen. Schrauben kreuzweise anziehen. Auf spannungsfreien Einbau achten!

Protect flange surfaces. Tighten screws crosswise. Make sure that the device is mounted free of strain!

Protéger les surfaces de brides. Serrer les vis en croix. S'assurer que le montage ne crée aucune tension mécanique.

Proteggere le superfici della flangia. Stringere le viti a croce. Eseguendo il montaggio evitare tensioni meccaniche!

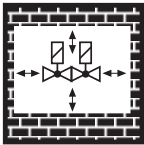

Direkter Kontakt zwischen MBC und dem aushärtendem Mauerwerk, Betonwänden, Fußböden ist nicht zulässig.

Do not allow any direct contact between the MBC and hardened masonry, concrete walls or floors.

Éviter tout contact direct entre le MBC et les maçonneries, cloisons en béton et sols en cours de séchage.

Non è consentito il contatto diretto fra l' MBC e murature invecchiate, pareti in calcestruzzo, pavimenti.



Grundsätzlich nach Teileausbau-/umbauneue Dichtungen verwenden.

Always use new seals after dismantling and mounting parts.

Après un démontage ou une modification, utiliser toujours des joints neufs.

In linea di massima, dopo lo smontaggio e il rimontaggio di alcune parti, utilizzare nuove guarnizioni.

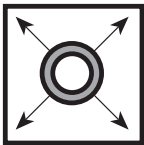

Rohrleitungsdichtheitsprüfung: Kugelhahn vor dem MBC schließen.

Pipeline leakage test: close ball valve upstream of MBC.

Contrôle d'étanchéité de la conduite : fermer le robinet à boisseau sphérique en amont du MBC.

Per la prova di tenuta delle tubature: chiudere il rubinetto a sfera davanti ai corpi MBC.



Nach Abschluß von Arbeiten am MBC: Dichtheitskontrolle und Funktionskontrolle durchführen.

On completion of work on the MBC, perform a leakage and function test.

Une fois les opérations terminées sur le MBC, procéder à un contrôle d'étanchéité et de fonctionnement.

Al termine dei lavori effettuati su una MBC predisporre un controllo sia della tenuta, sia del funzionamento.

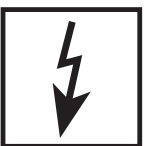

Niemals Arbeiten durchführen, wenn Gasdruck oder Spannung anliegt. Offenes Feuer vermeiden. Öffentliche Vorschriften beachten.

Never perform work if gas pressure or power is applied. No naked flame. Observe public regulations.

Ne jamais effectuer des travaux en présence de pression de gaz ou de tension électrique. Éviter toute flamme ouverte. Observer les réglementations.

In nessun caso si debbono effettuare lavori in presenza di pressione del gas o di tensione elettrica. Evitare le fiamme libere e osservare le prescrizioni vigenti.



Alle Einstellungen und Einstellwerte nur in Übereinstimmung mit der Betriebsanleitung des Kessel-/Brennerherstellers ausführen.

Any adjustment and application-specific adjustment values must be made in accordance with the appliance-/boiler manufacturers instructions.

Effectuer tous les réglages et réaliser les valeurs de réglage uniquement selon le mode d'emploi du fabricant de chaudières et de brûleurs.

Realizzare tutte le impostazioni e i valori impostati solo in conformità alle istruzioni per l'uso del costruttore della caldaia/ del bruciatore.



Bei Nichtbeachtung der Hinweise sind Personen- oder Sachfolgeschäden denkbar.

If these instructions are not heeded, the result may be personal injury or damage to property.

Le non-respect de ces consignes peut engendrer des dommages corporels ou matériels.

La non osservanza di quanto detto può implicare danni a persone o cose.



Die Druckgeräterichtlinie (PED) und die Richtlinie über die Gesamtenergieeffizienz von Gebäuden (EPBD) fordern eine regelmäßige Überprüfung der Wärmeerzeuger zur langfristigen Sicherstellung von hohem Nutzungsgraden und somit geringster Umweltbelastung.

**Es besteht die Notwendigkeit sicherheitsrelevante Komponenten nach Erreichen ihrer Nutzungsdauer auszutauschen:**

The Pressure Equipment Directive (PED) and the Energy Performance of Buildings Directive (EPBD) require a periodic inspection of heat generators in order to ensure a high degree of efficiency over a long term and, consequently, the least environmental pollution.

**It is necessary to replace safety-relevant components after they have reached the end of their useful life:**

La directive concernant les chauffe-bains à pression (PED) et la directive sur la performance énergétique des bâtiments (EPBD) exigent une vérification régulière des générateurs de chaleur afin de garantir à long terme des taux d'utilisation élevés et par conséquent une charge environnementale minimum. Il est nécessaire de remplacer les composants relatifs à la sécurité lorsqu'ils ont atteint la fin de leur vie utile:

La direttiva per apparecchi a pressione (PED) e la direttiva per l'efficienza dell'energia totale per edifici (EPBD), esigono il controllo regolare degli generatori di calore per la garanzia a lungo termine di un alto grado di rendimento e con ciò di basso inquinamento ambientale.

**Ciò rende necessaria la sostituzione di componenti rilevanti dal punto di vista della sicurezza alla scadenza della loro durata di utilizzazione:**

Sicherheitsrelevante Komponente Safety relevant component Composant relatif à la sécurité Componenti rilevanti dal punto di vista della sicurezza	Konstruktionsbedingte Lebensdauer Designed Lifetime Durée de vie prévue Durata di vita di progetto		CEN-Norm CEN-Standard CEN-Norme CEN-Norma
	Zyklenzahl Operating cycles Cycle d'opération Numero di cicli di funzionamento di progetto	Zeit [Jahre] Time [years] Durée [année] Periodo [anni]	
Ventilprüfsysteme / Valve proving systems Systèmes de contrôle de vannes / Sistemi di controllo valvole	250.000	10	EN 1643
Gas/Gaz Druckwächter / Pressure switch / Manostat / Pressostati	50.000	10	EN 1854
Luft/Air/Aria Druckwächter / Pressure switch / Manostat / Pressostati	250.000	10	EN 1854
Gasmangelschalter / Low gas pressure switch Pressostat gaz basse pression / Pressostati gas di minima pressione	N/A	10	EN 1854
Feuerungsmanager / Automatic burner control Dispositif de gestion de chauffage / Gestione bruciatore	250.000	10	EN 298 (Gas/Gaz) EN 230 (Öl/Oil/ Mazout/Olio)
UV-Flammenfühler <sup>1</sup> Flame detector (UV probes) <sup>1</sup> Capteur de flammes UV <sup>1</sup> Sensore fiamma UV <sup>1</sup>	N/A	10.000 Betriebsstunden Operating hours Heures de service Ore di esercizio	---
Gasdruckregelgeräte <sup>1</sup> / Gas pressure regulators <sup>1</sup> Dispositifs de réglage de pression du gaz <sup>1</sup> Regolatori della pressione del gas <sup>1</sup>	N/A	15	EN 88-1 EN 88-2
Gasventil mit Ventilprüfsystem <sup>2</sup> Gas valve with valve testing system <sup>2</sup> Vanne de gaz avec système de contrôle de vanne <sup>2</sup> Valvola del gas con sistema di controllo valvola <sup>2</sup>	nach erkanntem Fehler after error detection après détection d'erreur dopo segnalazione di errore		EN 1643
Gasventil ohne Ventilprüfsystem <sup>2</sup> Gas valve without valve testing system <sup>2</sup> Vanne de gaz sans système de contrôle de vanne <sup>2</sup> Valvola del gas senza sistema di controllo valvola <sup>2</sup>	50.000 - 200.000 abhängig von der Nennweite depends on diameter selon la taille a seconda della dimensione di connessione	10	EN 161
Gas-Luft-Verbundsysteme / Gas-air ratio control system Systèmes combinés gaz/air / Sistemi di miscelazione gas-aria	N/A	10	EN 88-1 EN 12067-2
<sup>1</sup> Nachlassende Betriebseigenschaften wegen Alterung / Performance decrease due to ageing Réduction de performance due au vieillissement / Riduzione delle prestazioni dovuta all'invecchiamento			
<sup>2</sup> Gasfamilien II, III / Gas families II, III / Familles de gaz II, III / per i gas delle famiglie II, III			
<b>N/A</b> nicht anwendbar / not applicable / ne peut pas être utilisé / non può essere usato			

Änderungen, die dem technischen Fortschritt dienen, vorbehalten / We reserve the right to make modifications in the course of technical development.  
Sous réserve de tout modification constituant un progrès technique / Ci riserviamo qualsiasi modifica tecnica e costruttiva

**Hausadresse**  
Head Offices and Factory  
Usine et Services Administratifs  
Amministrazione e Stabilimento

**Karl Dungs GmbH & Co. KG**  
Karl-Dungs-Platz 1  
D-73660 Urbach, Germany  
Telefon +49 (0)7181-804-0  
Telefax +49 (0)7181-804-166

**Briefadresse**  
Postal address  
Adresse postale  
Indirizzare la corrispondenza a

**Karl Dungs GmbH & Co. KG**  
Postfach 12 29  
D-73602 Schorndorf  
e-mail info@dungs.com  
Internet www.dungs.com





**Hausadresse**  
Head Offices and Factory  
Usine et Services Administratifs  
Amministrazione e Stabilimento

**Karl Dungs GmbH & Co. KG**  
Karl-Dungs-Platz 1  
D-73660 Urbach, Germany  
Telefon +49 (0)7181-804-0  
Telefax +49 (0)7181-804-166

**Briefadresse**  
Postal address  
Adresse postale  
Indirizzare la corrispondenza a

**Karl Dungs GmbH & Co. KG**  
Postfach 12 29  
D-73602 Schorndorf  
e-mail [info@dungs.com](mailto:info@dungs.com)  
Internet [www.dungs.com](http://www.dungs.com)